



robatherm AHUs.

Transport and unloading.

May 2024

English translation of the original German operating instructions

Air handling units | type RM/RL/TI-50

© Copyright by
robatherm GmbH + Co. KG
John-F.-Kennedy-Str. 1
89343 Jettingen-Scheppach
Germany



You can find the currently valid version of these instructions, and further instructions, on our website at www.robatherm.com/manuals.

This leaflet is based on the generally accepted engineering standards at the time of drafting. Since the printed version is not subject to change control, the current version must be requested from robatherm or downloaded from the Internet at www.robatherm.com before application.

This publication, including all illustrations, is protected by copyright. Any use outside the scope permitted by the Copyright Act without our consent is illegal and punishable by law. This applies in particular to reproductions, translations, microfilming, storing, and processing in electronic systems.

Content subject to change.

To improve readability, this document does not use male, female, and non-binary pronouns (m/f/d). All pronouns apply equally to all genders.

Last modified: May 2024

Contents

General remarks	4
Information about these instructions	4
Environmental protection	5
Personnel qualification	5
Security	6
General risk sources	6
Installation site requirements	10
Types of unloading	11
Unloading sequence	12
Crane unloading and transport	13
Personnel qualification	13
Unloading by means of transport lugs	13
Unloading by means of transport loops	15
Craning of rotary heat exchangers	21
Craning hydraulics on a skid	21
Forklift unloading and transport	22
Personnel qualification	22
General remarks about forklift unloading	22
Packaging and storage	24
Directory	25
List of figures	25
Keyword index	26

General remarks

Information about these instructions

These instructions will facilitate safe and efficient use of the AHU.



All persons working on the AHU must thoroughly read and understand these instructions before starting any kind of work.

Safe working is dependent on adhering to all safety information and instructions.

Accident prevention regulations

In addition to the information in these instructions, the local accident prevention and national occupational health and safety regulations apply.

Further information

The instructions describe all the available options. Whether and which options are available in the AHU depends on the options selected and the country for which the AHU is intended. The illustrations serve as an example and may differ.

The instructions consist of several parts and have the following structure:



Fig. 1: Parts of the instructions

Main operating instructions

- ➔ Transport and unloading
- ➔ Installation and assembly
- ➔ Commissioning
- ➔ Operation and faults
- ➔ Maintenance and cleaning
- ➔ Disabling and disposal

Environmental protection

NOTE



Risk to the environment due to incorrect handling of environmentally hazardous substances.

Improper handling of environmentally hazardous substances can cause damage to the environment. Incorrect disposal of environmentally hazardous substances can endanger the environment.

- Observe the instructions in the operating manual.
- Environmentally hazardous substances must be disposed of by a waste disposal and recycling company.
- In case of leakage of environmentally hazardous substances, take appropriate measures (see chapter "Chemical hazard due to operating fluids ", page 9) and inform competent authorities.

Personnel qualification

AHUs may only be transported by persons with appropriate qualifications.

→ Professional driver

The professional driver has a valid driver's license for the motor vehicle according to Directive 2003/59/EC with entry of code number 95 in the driver's license. Professional drivers are trained for the specific task area in which they work and know the relevant standards and regulations. The professional driver has in-depth knowledge of transport and load securing. The professional driver is able to carry out transport work on the basis of professional training, knowledge and experience and to recognize and avoid possible dangers independently.

Security

General risk sources

General hazards

WARNING



Danger of crushing from reaching under suspended loads

When positioning the delivery sections for the installation and assembly of the AHU, there is a risk of crushing people or limbs if people are in the danger zone or limbs reach into the danger zone.



- Leave the danger zone.
- Do not reach under the delivery section.
- Do not stand below suspended loads.
- Wear safety footwear of a min. protection class S1 according to EN ISO 20345.
- Observe the safety regulations for the industrial truck and means of transport.



WARNING



Danger to life from falling!

A falling height of more than 1 m constitutes a fall hazard.

- For falling heights of 1 m or more, a railing is recommended.
- From falling heights of 3 m, fall protection can be implemented using anchor points.

WARNING



Danger to life due to incorrect storage and transport

If a roof load is applied to a correspondingly marked section (e.g., by stacking), this will cause the structure to fail. When craning the section, failure of the casing construction and falling of the section or parts of it may cause danger to life.



- Do not load the roof.

WARNING



Danger to life from wrong transportation

If the transport loops are loaded incorrectly (e.g. for lashing on a lorry), this will cause the structure to fail. When craning a unit on DIN frame, failure of the transport loops and the unit on DIN frame or parts of it falling may cause danger to life.

- Do not use transport loops for load securing on the lorry.

WARNING**Danger to life from suspended loads and falling objects**

Danger to life from failing transport lugs or transport loops.

- No additional loads on in or on the delivery sections.
- Do not install any components in or on the delivery section before transporting it to the final installation site.
- Only use suitable permitted lifting equipment (rope, chains, lifting straps, turnbuckles) complying with BGV D6 (German employers' liability insurance association regulations) to transport and unload the delivery sections.
- Only attach lifting equipment to the transport lugs on the delivery sections.
- Lifting equipment must be approved for the weight of the delivery section.
- For transport lugs, the angle of inclination between the lifting equipment and load must be between 45° and 55°.
- For transport loops, the maximum permitted oblique pull is 10°.
- Reduce the load capacity by spreading the lifting equipment in accordance with the lifting equipment table.
- Observe the safety regulations for the conveyor vehicles and means of transport.
- Do not stand below suspended loads.

**WARNING****Danger to life from falling objects**

There is a danger to life from the delivery section falling over during unloading and transport with the forklift due to it having an offset centre of gravity or a narrow footprint.

- No additional loads on in or on the delivery sections.
- Do not install any components in or on the delivery section before transporting it to the final installation site.
- For delivery sections with a narrow footprint, first secure with suitable auxiliary tools and materials provided on site to prevent falling over (rope, supports, etc.).
- Only unload the delivery section from the base frame or pallet or transport using these.
- If the centre of gravity is off-centre, reposition the forks.
- Lower the delivery section completely.
- Tilt the lifting mast slightly towards the forklift and secure the delivery section at the lifting mast to prevent it from tipping over.
- Observe the forklift safety instructions.

WARNING**Danger to life due to loose parts falling over**

Removing transport locks from loose parts before final unloading at the installation site poses a risk of fatal injury from falling over.

- When unloading by crane, attach loose parts to the crane first.
- When unloading with the forklift, first secure loose parts against falling over with suitable on-site aids (ropes, supports, ...)
- Then remove transport locks.

CAUTION



Risk of cutting due to sharp edges

There is a risk of being cut by the sharp edges when touching the metal edges.

- Wear personal protective equipment (cut-resistant gloves and long-sleeved clothing).

NOTE



Material damage due to incorrect transport

All sections are equipped with transport lugs or transport loops. Sections without their own base frame are equipped for transport with disposable pallets. Incorrect transport can cause damage to property.

- Transport the sections in such a way that the base frame/DIN frame or the squared lumber/pallet is always at the bottom and the transport lugs are always at the top.
- Unloading and transport according to these instructions.
- When unloading with a forklift, drive the forks underneath the whole delivery bloc.

Chemical hazard due to operating fluids

WARNING



Damage to health from mercury

UV-C illuminants contain mercury. Mercury is toxic and dangerous to the environment.

- Avoid contact with skin and eyes. In case of contact, flush skin and eyes with plenty of water. Take off contaminated clothing.
- Do not swallow. If swallowed, induce vomiting.
- Ensure good air exchange in the danger zone.
- Comply with the safety data sheet of the manufacturer.

CAUTION



Risk of serious injuries due to hazardous substances

There is a risk of poisoning if the carton is damaged or if the UV-C illuminants break.

- When handling broken UV-C illuminants, follow the safety instructions for handling mercury.
- Avoid direct contact with eyes, skin, and clothing.
- Ensure excellent ventilation of the AHU and the rooms connected via the ducts.
- Keep broken pieces of UV-C illuminants in airtight packaging and dispose of properly.

TIP

Removal of small amounts of mercury



UV-C illuminants contain small amounts of mercury. Removal of the small amount leaked at breakage can be done with special sorbents for mercury.

Installation site requirements

For information on the installation site, see "Installation and assembly" chapter "Requirements for the installation site".

Types of unloading

Individual sections are to be loaded onto the truck in such a way that they can be unloaded depending on the selected unloading method. The following types of unloading are possible:

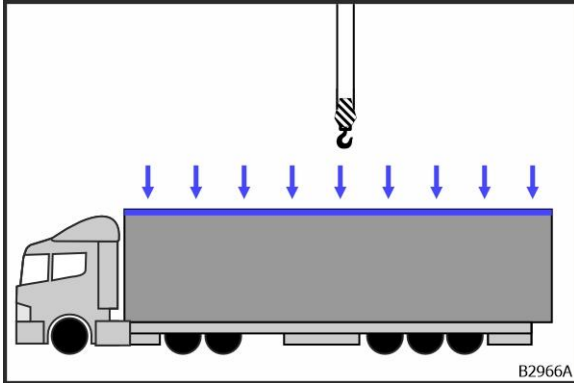

Fig. 2: Crane unloading

- Unloading via the roof by means of transport lugs see chapter "Unloading by means of transport lugs", page 13.

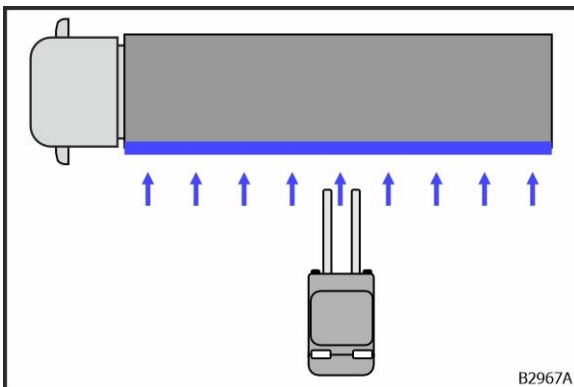

Fig. 3: Forklift unloading from the side

- Unload from the side using base frame or pallet see chapter "Forklift unloading and transport ", page 22.

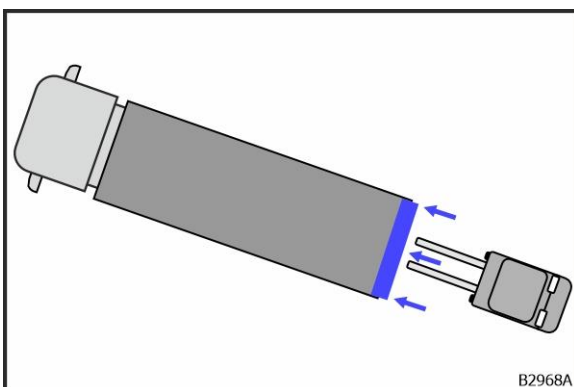
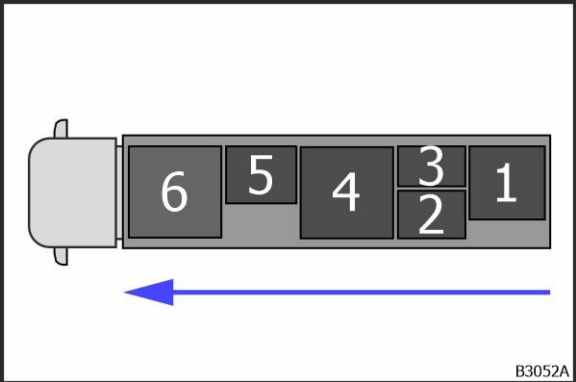

Fig. 4: Forklift unloading from the back

- Unloading via the rear end by means of base frame or pallet see chapter "Forklift unloading and transport ", page 22.

Units on DIN frame are unloaded by means of transport loops, see chapter "Unloading by means of transport loops", page 15.

Unloading sequence



Start unloading the truck from the rear.

Fig. 5: Unloading sequence

Crane unloading and transport

Personnel qualification

The work described in this section may only be performed if the person has the following qualifications:

- Crane operator

Crane operators are trained for the specific task area in which they work and know the relevant standards and regulations. Based on a theoretical and practical examination, the crane operator has in-depth knowledge of load suspension devices and lifting equipment as well as of estimating, slinging, setting down and storing loads. The crane operator is able to carry out transport work on the basis of professional training, knowledge and experience and to recognize and avoid possible dangers independently.

Unloading by means of transport lugs

Each section is equipped with four transport lugs. The transport lugs are located in the corners on the roof of the section.

Aids for unloading by means of transport lugs

- 4x shackles for transport lugs with \varnothing 30 mm
- Other suitable lifting equipment

Craning of sections by means of transport lugs

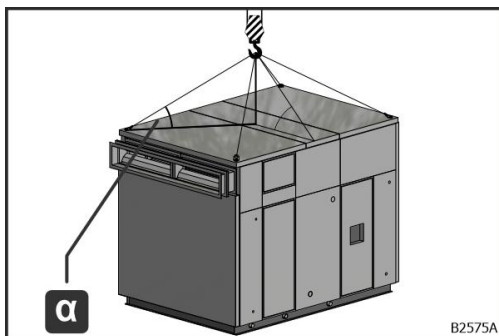

Attach lifting equipment to all transport lugs. The angle of inclination α between the lifting equipment and the load must be between 45° and 55° , otherwise use lifting gear.

Fig. 6: Cranes with transport lugs

Craning of sections with roof rack frames

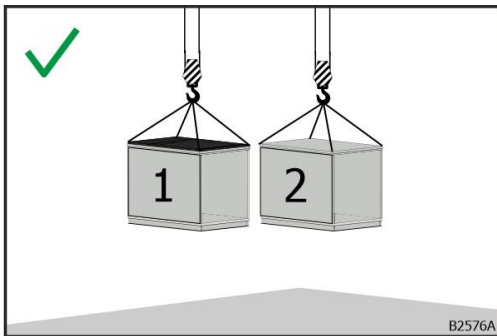

Fig. 7: Craning sections

Always crane sections individually. The upper section (2) must not be connected to the lower section (1) until the lower section (1) is at the final installation site.

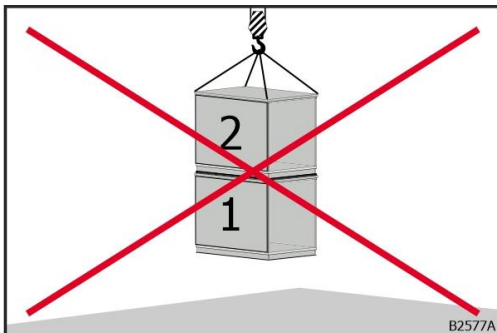

Fig. 8: Incorrect craning of sections

The roof rack frame is not designed to lift the lower section (1) together with the upper section (2).

Unloading by means of transport loops

WARNING



Danger to life due to incorrectly struck load

Due to the inclined position of the unit on DIN frame, the transport loops are not loaded evenly. There is a risk of death due to the failure of transport loops.

- Determine the center of gravity.
- Correct inclined position by changing the rope length.
- For uniform loading, use turnbuckles as lifting equipment.
- Use lifting gear.

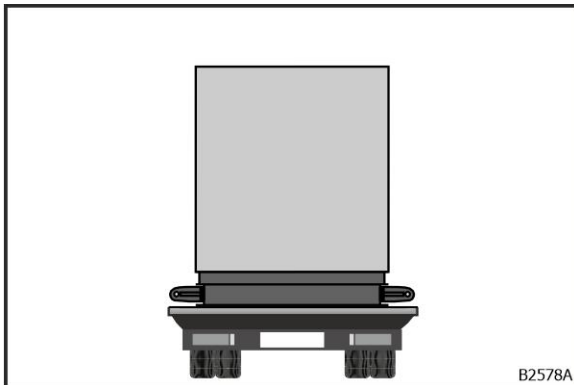

Fig. 9: Unit on DIN frame on a lorry

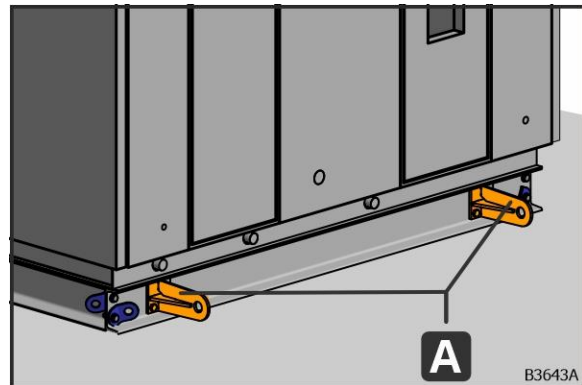

Fig. 10: Transport loops (A)

For AHUs completely mounted on a DIN frame, the transport loops (A) must be used.

The positions of the transport loops (A) on units on DIN frames are designed exclusively for transport and cannot be used for positioning the support structure (support point).

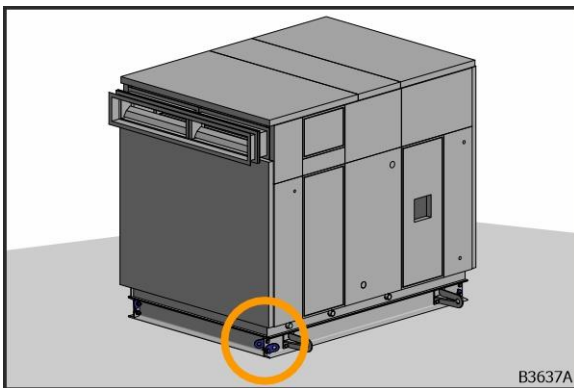

Fig. 11: Corner of the DIN frame

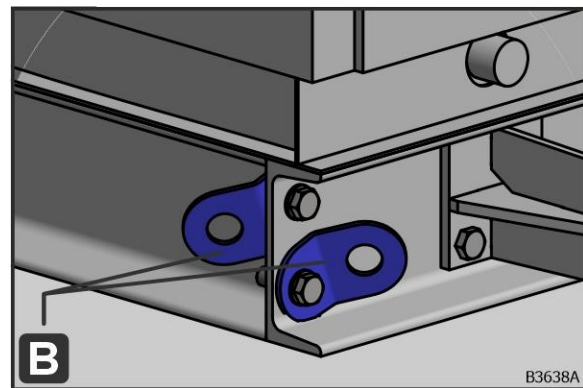

Fig. 12: Transport lugs (B) on the DIN frame

Every corner of the DIN frame is fitted with transport lugs (B). The transport lugs (B) on the DIN frame are only used to attach ropes for positioning.

Auxiliary tools for unloading units on DIN frame by means of transport loops

Traverse requirements

Use traverses with load capacity \geq transport weight. Directly connecting the crane hook to the lifting points is not permitted. Reduce the load capacity by spreading the lifting equipment in accordance with the lifting equipment table.

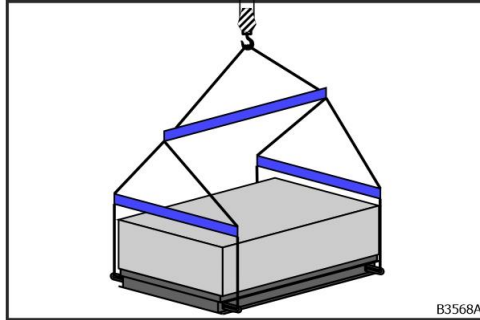

Fig. 13: Example of on-site lifting devices for 4 transport loops

In the case of units on DIN frames, it is absolutely essential that a suitable on site lifting device (e.g. loading gear) is used to ensure even load distribution across all transport loops. The traverses must have a sufficient number of lifting points. All transport loops must be used for the crane procedure. Refer to the technical drawing for the number of transport loops.

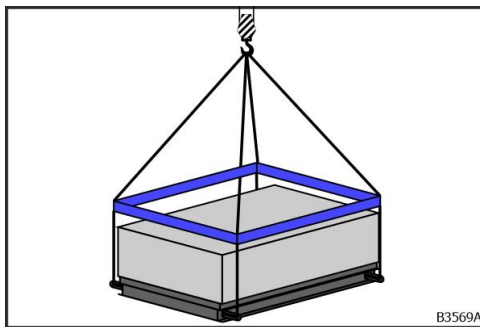

Fig. 14: Example of on-site lifting devices for 4 transport loops

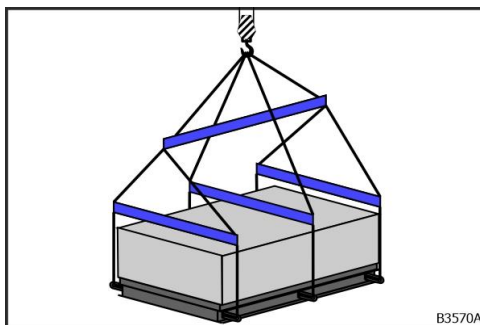

Fig. 15: Example of on-site lifting devices for 6 transport loops

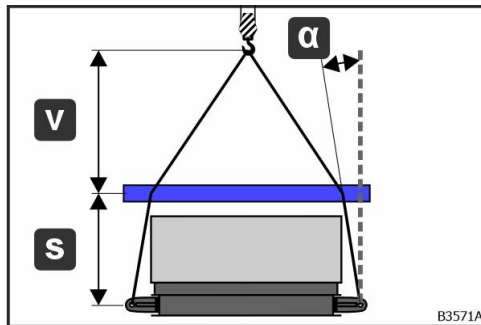

Fig. 16: Selecting the traverses

Use traverses with attachment elements that can be adjusted in width and length.

- Angle α must not be negative ($\alpha \geq 0^\circ$).
- Choose a very small distance s .
- Choose a very large distance v .
- $v > s$

The width and length of the traverses must be right for the distance between the transport loops to prevent oblique pull.

Requirements for other lifting equipment

- Use chains with load tensioners to adjust the chain length.
- Polyester slings are not suitable.

Craning units on DIN frame using transport loops

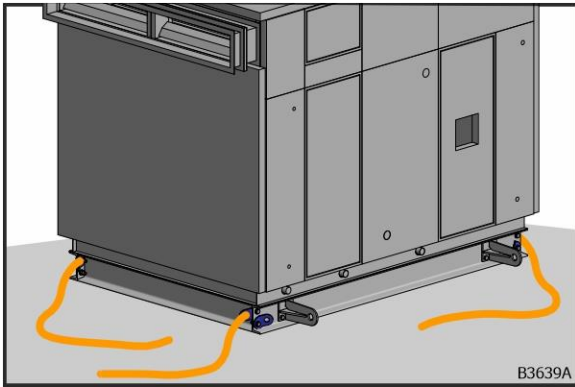

Fig. 17: Guide rope for positioning

1. Before the crane operation, attach guide ropes to each corner of the DIN frame in the transport lugs (B) for positioning.

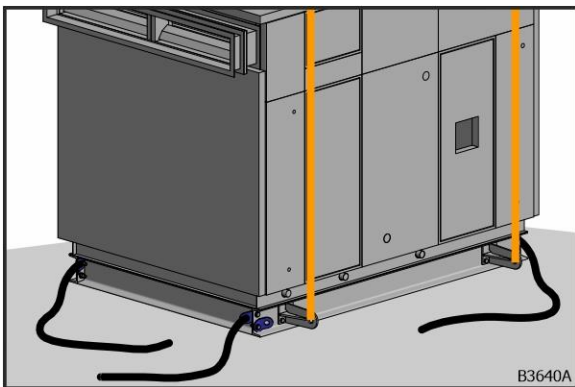

Fig. 18: Attaching the unit on DIN frame to the transport loops

2. Attach the unit on DIN frame to the transport loop (A) see chapter "Auxiliary tools for unloading units on DIN frame by means of transport loops", page 16.

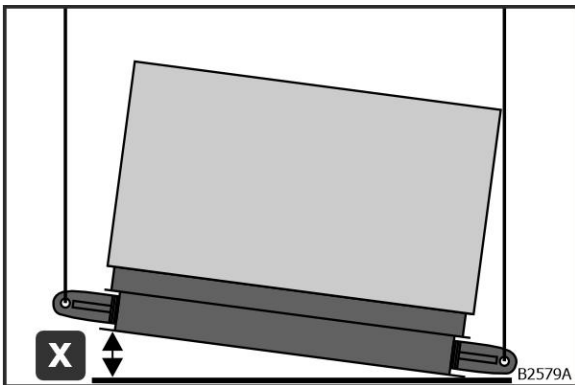

Fig. 19: Inclined position in width direction

- The maximum permissible inclined position when craning units on DIN frame in the width direction is $x \leq 5$ cm.

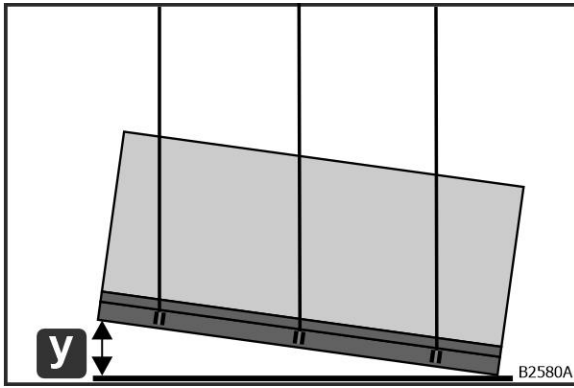

Fig. 20: Inclined position in length direction

- The maximum permissible inclined position when craning DIN frame equipment in the length direction is $y \leq 30$ cm

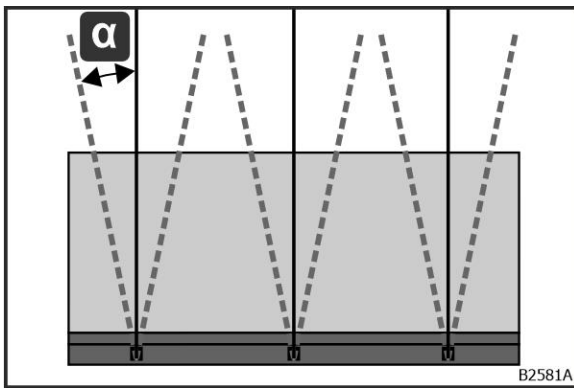

Fig. 21: Oblique pull

- The maximum permissible oblique pull for lifting equipment with cranes for units on DIN frames is $\alpha \leq 10^\circ$.
3. Adjust the lifting equipment so that the AHU is craned horizontally to prevent it from tipping over.

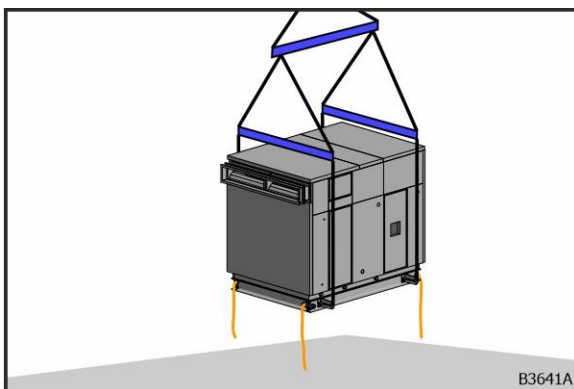

Fig. 22: Unit on DIN frame on the crane

4. Hold the guide rope.

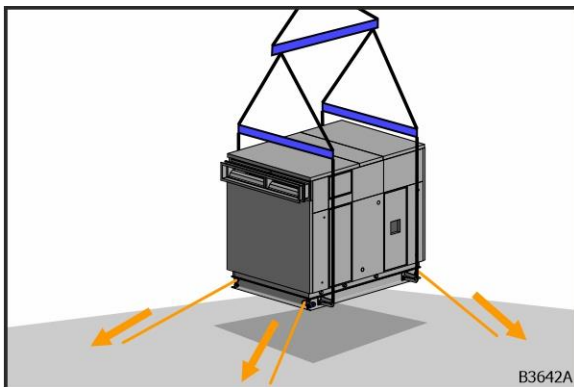

Fig. 23: Positioning using guide ropes

5. Turn and position the unit on DIN frame using the guide ropes.

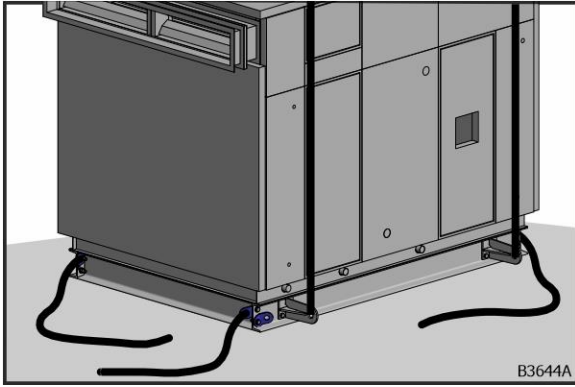

Fig. 24: Unit on DIN frame set down

6. Set down the unit on DIN frame.

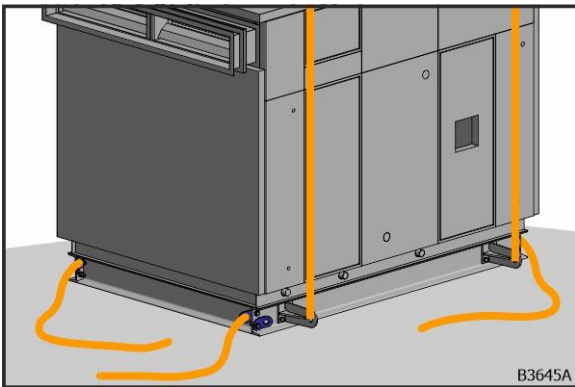

Fig. 25: Guide rope and lifting equipment

7. Remove the guide rope and lifting equipment.

Craning of rotary heat exchangers

To prevent loose rotary heat exchangers from falling over, proceed as follows:

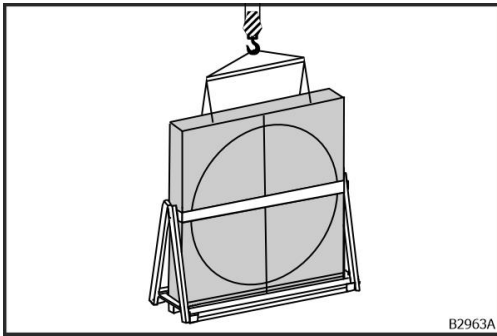

Fig. 26: Attaching the rotary heat exchanger to the crane

1. Attach the rotary heat exchanger to the crane. For slinging on the crane per rotor casing, see attachment "Hoval - Rotary heat exchanger - Instructions for installation, commissioning and scheduled maintenance" chapter "Lifting the exchanger".

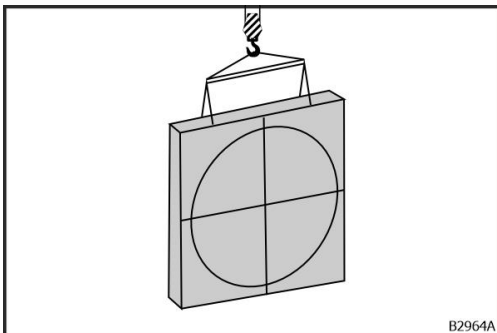

Fig. 27: Removing transport lock

2. Remove the transport lock.

→ The rotary heat exchanger can be craned safely.

In the case of two-part rotary heat exchangers, the segments of the accumulation mass are supplied in a wooden box.

Craning hydraulics on a skid

NOTE



Material damage when craning hydraulics on a skid

When craning hydraulics on a skid, material damage can occur due to the load suspension and lifting equipment.

- Do not crane hydraulics on a skid.

Forklift unloading and transport

Personnel qualification

The work described in this section may only be performed if the person has the following qualifications:

- Forklift driver

Forklift drivers are trained for the specific task area in which they work and know the relevant standards and regulations. Based on a theoretical and practical examination, the forklift driver has in-depth knowledge of industrial trucks as well as of estimating, lifting, transporting, setting down and storing loads. The forklift driver is able to perform transport work based on professional training, knowledge and experience, and to recognize and avoid possible hazards independently.

General remarks about forklift unloading

Delivery sections with base frames are equipped with wood beams for transport to allow the forks of the industrial truck to pass underneath.

Delivery sections without a base frame are equipped with disposable pallets for transport.

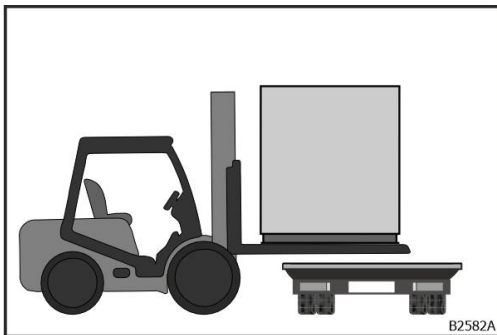

Drive the section completely underneath to avoid damage to the casing. The forks of the forklift may only engage the base frame or the pallet.

Fig. 28: Unloading with forklift

Forklift unloading of hydraulics on a skid

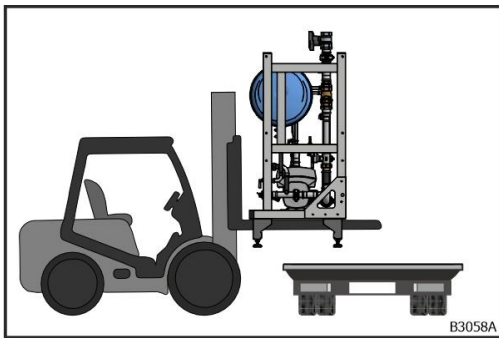

Fully retract hydraulics on a skid to avoid damage. The forks of the forklift may only engage the lower rack or the pallet.

Fig. 29: Unloading hydraulics on a skid with the forklift

Packaging and storage

Sections are packed in foil for transport. This packaging does not meet the requirements for storing the sections outdoors. The storage location must meet the requirements for the installation site for indoor units (see "Installation and assembly" chapter "Requirements for the installation site").

If the sections are stored for an extended period, the instructions "Disabling and disposal" from chapter "Disabling" apply.

Directory

List of figures

Fig. 1: Parts of the instructions	4
Fig. 2: Crane unloading	11
Fig. 3: Forklift unloading from the side	11
Fig. 4: Forklift unloading from the back	11
Fig. 5: Unloading sequence	12
Fig. 6: Cranes with transport lugs	13
Fig. 7: Craning sections	14
Fig. 8: Incorrect craning of sections	14
Fig. 9: Unit on DIN frame on a lorry	15
Fig. 10: Transport loops (A)	15
Fig. 11: Corner of the DIN frame	15
Fig. 12: Transport lugs (B) on the DIN frame	15
Fig. 13: Example of on-site lifting devices for 4 transport loops	16
Fig. 14: Example of on-site lifting devices for 4 transport loops	16
Fig. 15: Example of on-site lifting devices for 6 transport loops	16
Fig. 16: Selecting the traverses	17
Fig. 17: Guide rope for positioning	18
Fig. 18: Attaching the unit on DIN frame to the transport loops	18
Fig. 19: Inclined position in width direction	18
Fig. 20: Inclined position in length direction	19
Fig. 21: Oblique pull	19
Fig. 22: Unit on DIN frame on the crane	19
Fig. 23: Positioning using guide ropes	19
Fig. 24: Unit on DIN frame set down	20
Fig. 25: Guide rope and lifting equipment	20
Fig. 26: Attaching the rotary heat exchanger to the crane	21
Fig. 27: Removing transport lock	21
Fig. 28: Unloading with forklift	22
Fig. 29: Unloading hydraulics on a skid with the forklift	23

Keyword index

B

Base frame7

C

Conveyor vehicles.....7

Crane8

Crane operator..... 13

Crane unloading..... 13

Craning..... 14

D

Danger

 Chemical hazards 5, 9

Delivery section.....7

Directory..... 25

F

Forklift.....7, 8

Forklift driver 22

Forklift transport 11, 22

Forklift unloading 11, 22

I

Installation site7

Instructions.....4

 Commissioning4

 Disabling and disposal4

 Installation and assembly.....4

 Maintenance and cleaning.....4

 Operation and incidents4

 Transport and unloading4

L

Lifting equipment7

List of figures 25

Load capacity.....7

M

Main operating instructions..... 4

O

Operating fluids 5, 9

P

Personnel qualification 5, 13, 22

Professional driver 5

R

Roof rack frame..... 14

Rotary heat exchanger 21

S

Section.....8, 14

T

Transport 7, 8

 Crane 8

 Forklift 7, 8, 11, 22

 Transport by crane..... 13

Transport by crane 13

Transport lock 7

Transport loops 7, 8, 11, 15

Transport lugs 7, 8, 11, 13

U

Unit on DIN frame 15

Unloading..... 7, 8, 11, 13, 15

 Crane 7, 8

 Crane unloading..... 13

 Forklift 7, 8, 11, 22

 Transport loops.....11, 15

 Transport lugs 11, 13

UV-C illuminants 9

robatherm
John-F.-Kennedy-Str. 1
89343 Jettingen-Scheppach

Tel. +49 8222 999 - 0
info@robatherm.com
www.robatherm.com

robatherm
the air handling company