



the air handling company

**robatherm ATEX unit.**

**Maintenance and cleaning.**

**July 2024**

**English - Translation of the original instructions**

Air handling units for potentially explosive atmospheres | Type TI-50

© Copyright by  
robatherm GmbH + Co. KG  
John-F.-Kennedy-Str. 1  
89343 Jettingen-Scheppach  
Germany



You can find the currently valid version of these instructions, and further instructions, on our website at [www.robatherm.com/manuals](http://www.robatherm.com/manuals).

This leaflet is based on the generally accepted engineering standards at the time of drafting. Since the printed version is not subject to change control, the current version must be requested from robatherm or downloaded from the Internet at [www.robatherm.com](http://www.robatherm.com) before application.

This publication, including all illustrations, is protected by copyright. Any use outside the scope permitted by the Copyright Act without our consent is illegal and punishable by law. This applies in particular to reproductions, translations, microfilming, storing, and processing in electronic systems.

Content subject to change.

To improve readability, this document does not use male, female, and non-binary pronouns (m/f/d). All pronouns apply equally to all genders.

Last modified: July 2024

# Contents

General remarks	5
Information about these instructions	5
Security	6
General risk sources	6
Personnel qualification	12
Maintenance interval	12
Leak tightness test	12
Casing	13
Inspection	13
Cleaning and scheduled maintenance	14
Repair	15
Filter component	17
Spare filter	17
Inspection	18
Repair	19
Silencer	25
Inspection	25
Cleaning	26
Repair	27
Fan	28
Inspection	29
Repair	33
Motor removal device	35
Motor removal device with lift out device	51
Heat recovery systems (HRS)	79
Plate heat exchanger	79
Heating and cooling coils	80
Heating coil	81
Cooling coil	85
Dampers	89
Damper	89
Hydraulic set	92
Exhaust ventilating	92
Inspection	93
Repair	93
Control system	94
Maintenance interval	94
Inspection	94
Repair	96
Pressure measuring devices	97
Electrical safety tests	111
Personnel qualification	111
Maintenance interval	111
Work steps	111

Directory	113
List of figures	113
Keyword index	118

# General remarks

## Information about these instructions

These instructions will facilitate safe and efficient use of the AHU.



All persons working on the AHU must thoroughly read and understand these instructions before starting any kind of work.

Safe working is dependent on adhering to all safety information and instructions.

## Further information

The instructions describe all the available options. Whether and which options are available in the AHU depends on the options selected and the country for which the AHU is intended. The illustrations serve as an example and may differ.

The instructions consist of several parts and have the following structure:



Fig. 1: Parts of the instructions

Main operating instructions

- Transport and unloading
- Installation and assembly
- Commissioning
- Operation and faults
- Maintenance and cleaning
- Disabling and disposal

# Security

## General risk sources

### Electrical hazards due to electric current and voltage

#### DANGER



##### **Risk of electric shock**

Risk of death from electric current when touching parts with live voltage. If the insulation is damaged, there is risk of death from electric current.

- When the insulation is damaged, turn the voltage supply off immediately, and arrange for repair.
- Before carrying out any work on the AHU, disconnect power and voltage supply as follows:
  - Turn the main switch to position "0".
  - Secure the main switch with a lock.
  - Disconnect AHU from power and voltage supply of the supply line.
  - Ensure that the unit is disconnected.
  - Ground and short-circuit.
  - Do not bridge or switch off fuses.
  - Keep moisture away from live parts.

#### DANGER



##### **Danger to life due to stored electric charge!**

DC link capacitors of the frequency converter can remain charged even when the mains supply is switched off and disconnected. There is a risk of death if the discharging time is not observed.

- Wait for a discharging time of 15 minutes.

#### WARNING



##### **Risk of electric shock**

When the main switch is switched off, the following parts are still live and can cause injury from electric current: electrical conductors and terminals upstream of the main switch, switch cabinet lamps, surge arresters including their connected wires, cables and terminals.

- Do not touch live parts.
- Work on the switch cabinet may only be carried out by a qualified electrician.

## Hazards from explosive atmosphere

### WARNING



#### Risk of explosion from explosive atmosphere

There is a risk of explosion, as the AHU may convey a potentially explosive atmosphere.

- Purge the AHU with fresh air before opening to remove any potentially explosive atmosphere.
- Only open the AHU if it is certain that there is no potentially explosive atmosphere.
- Follow the instructions in the operating instructions.

### WARNING



#### Risk of explosion from explosive atmosphere

There is a risk of explosion, as the AHU may convey a potentially explosive atmosphere. In conjunction with a source of ignition, this may result in an explosion.



- Before carrying out any work on the AHU, disconnect the power and voltage supply as follows:
  - Turn the main switch to position O.
  - Secure the main switch with a lock.
  - Disconnect the AHU from the power and voltage supply of the supply line.
  - Verify voltage-free state.
  - Earth and short circuit.
  - Never bypass or disable fuses.
  - Keep moisture away from conductive parts.
- Use electrostatically dissipative safety footwear.
- Use electrostatically dissipative protective clothing.
- Use tools complying with DIN EN 1127-1 Annex A.
- Do not take sources of ignition into the danger zone (e.g. hot surfaces, spark discharge, naked flame).
- Alternatively: gauge the danger zone to eliminate a potentially explosive atmosphere.

### WARNING



#### Risk of explosion when AHU not running

There is a risk of explosion, as the AHU may convey a potentially explosive atmosphere. When not in operation, the concentration of the potentially explosive atmosphere can change both in the AHU and in the machine room due to leakages.



- Purge the AHU with fresh air before opening to remove any potentially explosive atmosphere.
- Use electrostatically dissipative safety footwear.
- Use electrostatically dissipative protective clothing.
- Use tools complying with DIN EN 1127-1 Annex A.

**WARNING**



**Risk of explosion from corroded connecting elements**

The connecting elements establish an electrical connection between the individual components and ensure that all conductive components of the AHU are connected to the AHU's equipotential bonding. Corrosion reduces the efficacy of the electrical connection. Corroded connecting elements may cause static charging of the AHU. The discharge and the resulting sparks may cause an explosion.

- Replace connecting elements.



## Mechanical hazards due to machine movements

### WARNING



#### **Risk of death due to sudden switch-on**

When AHU is switched off, or the electrical power supply fails, certain control functions (e.g., timer programs, pump-out, fan overshoot, frost protection) or power restoration can cause components to switch on immediately. This poses danger to life.

- Carry out the steps "Securing the AHU against restarting" (see "Main operating instructions", section "Securing against restarting").

### WARNING



#### **Danger from moving parts**

After switching off the AHU, there is still a risk of death due to moving parts, as the components do not have immediate stop functions.

- Wait for all moving parts (e.g., fan, rotary heat exchanger, motor, belt drive) to come to a standstill.

## Thermal hazards due to hot and cold surfaces

### CAUTION



#### **Risk of burns due to hot surfaces**

Hot surfaces of components (e.g., heating coils, direct firing, pressure steam humidifiers, steam heaters) pose a risk of burn injuries during operation and even after the AHU has been switched off.

- Let the fan run to cool down to room temperature.
- Do not touch the hot surface.

### CAUTION



#### **Risk of burns due to hot surfaces**

There is a risk of burns when touching hot pipes.

- Pipes outside the AHU must be insulated by the customer to make them impermeable.

## General hazards

### WARNING



#### **Risk of injury due to modifications or use of incorrect spare parts**

Serious injuries, death, and material damage can be caused by modifications or installation of incorrect spare parts.

- Use original spare parts only.
- Do not make any modifications.

### WARNING



#### **Danger to life from falling!**

If a grate above an air opening is overloaded downwards (>400kg), this will cause the structure to fail. When a person steps on the grate, the structure may fail, causing a risk to life by falling through the air opening.

- Do not exceed the maximum load ( $\leq 400\text{kg}$  or 2 persons).

### WARNING



#### **Danger to life from falling!**

Removing the grates in the floor causes a risk to life from falling, as the opening in the floor is exposed.

- When working on air openings with removed grates, the customer must provide protection against falling.
- After the work, mount the grates again according to the instructions.

### WARNING



#### **Danger to life from falling!**

When stepping on the protection roof, there is a risk to life from falling, as the protection roof is unsuitable for supporting loads.

- Do not enter the protection roof.

### NOTE



#### **Material damage due to localized weight**

If more than one person enters the AHU at a time or localized loads are otherwise applied, pans and floors may be deformed.

- Do not let several persons enter the AHU at the same time.
- If this becomes necessary, take suitable measures to distribute the weight (e.g., grates, wooden boards, wood beams).

## Personnel qualification

The work described in this section may only be performed if the person has the following qualifications:

- Qualified person in accordance with pressure equipment regulation
- Qualified person in explosion protection
- Qualified electrician
- Qualified electrician in explosion protection
- Hygiene specialist
- Mechanic
- Cleaning specialist
- Person trained in explosion protection

## Maintenance interval

AHUs are machines that require regular maintenance. The specified intervals are approximate and refer to normally polluted air inspired by VDI 6022. If the air is very polluted, the intervals must be shortened accordingly. Regular maintenance does not release the operator from his duty of care to check the system daily for function or damage.

## Leak tightness test

In hygienically relevant areas where a transfer of substances from the extract air to the supply air is not permissible, the components concerned must be checked for tightness annually or after each scheduled maintenance (e.g., using suitable test gas). Observe the manufacturer's safety information. If necessary, take appropriate measures to restore the required tightness in consultation with the manufacturer.

# Casing

## Inspection

### WARNING



#### **Risk of explosion from lack of equipotential bonding**

Non-existent or incorrectly connected equipotential bonding may cause components to become statically charged. The discharge may cause an explosion.



- Connect all factory installed equipotential bonding conductors and secure them to prevent them from loosening.
- Observe the work steps set out in the operating instructions.

### Maintenance interval

Monthly.

### Work steps

1. Check that all equipotential bonding conductors, earthing straps and earthing screws are tight and secure.
2. Check the connecting elements for corrosion.
3. Replace corroded connecting elements.

### Maintenance interval

Every three months.

### Work steps

- Perform an electrical safety check of the connection to the equipotential bonding conductor of the AHU see chapter "Electrical safety tests ", page 111.

## Cleaning and scheduled maintenance

### WARNING



#### **Risk of explosion from electrostatic discharge**

Cleaning the AHU with a dry cloth may cause a static charge. The discharge and the resulting sparks may cause an explosion.

- Only wipe the AHU with a damp cloth.
- Follow the instructions in the operating instructions.

### Maintenance interval

Every three months.

### Work steps

- Remove dry coarse soiling with an industrial vacuum cleaner.
- For other contamination: use a damp cloth; if necessary, use grease- and oil-dissolving cleaning agents with a pH between 7 and 9.
- In the case of pans that are difficult to access (e.g., underneath coils), the corresponding components may need to be removed for complete cleaning.
- Treat galvanized parts with clear coat (...).
- Regularly treat all moving parts, such as lever locks and hinges, with lubricant.
- Check seals, especially door seals, regularly for damage and function.
- Immediately repair damage to the coating or corrosion with varnish.
- Remove contamination from joints of built-in parts (e.g., transition panel/unit lighting) with industrial vacuum cleaner and joint nozzle, if necessary spray bottle with cleaning agent and a damp cloth.

### Disinfection

Only use alcohol-based disinfectants with country-specific approval (e.g., RKI, VAH, DGKH).

# Repair

## Locking systems for doors

### Lever lock for the outside

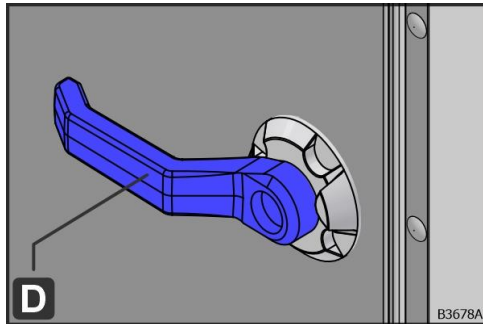

Fig. 2: Standard lever lock

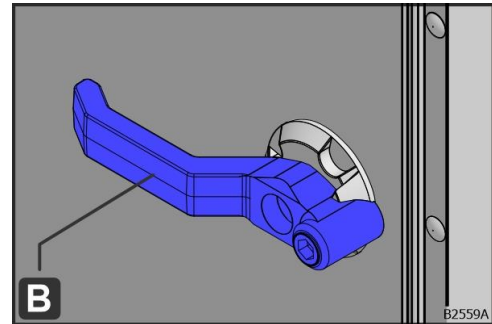

Fig. 3: Lever lock with key size 10 / double-bit 3

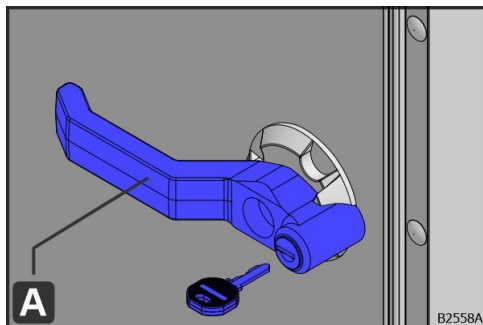

Fig. 4: Lever lock with key cylinder

### Combinations on the inside

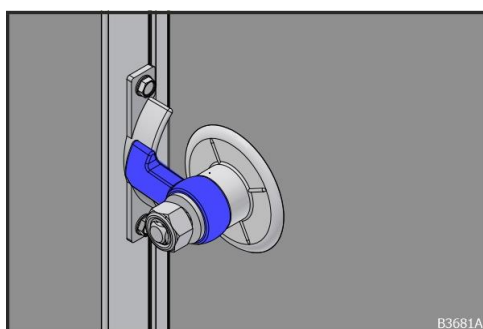

Fig. 5: Locking cam catch (suction side)

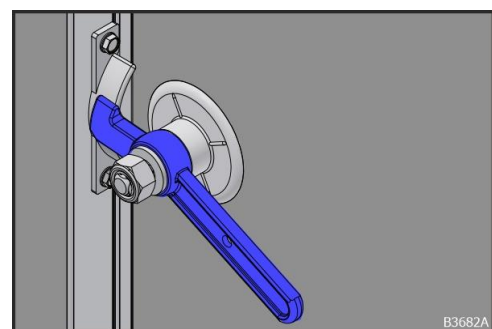

Fig. 6: Locking cam catch with emergency lever lock (suction side)

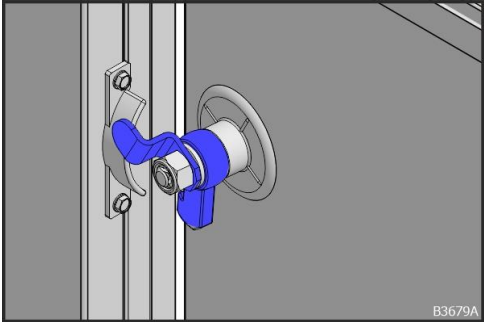

Fig. 7: Locking cam catch with retaining mechanism (discharge side)

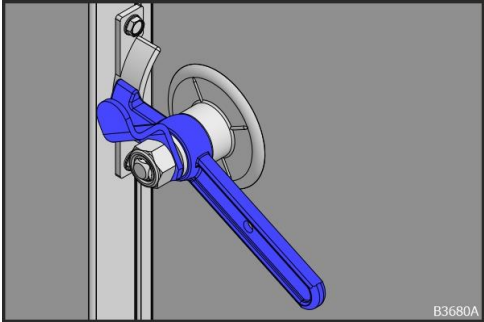

Fig. 8: Locking cam catch with emergency lever lock and retaining mechanism (discharge side)

**External lock**

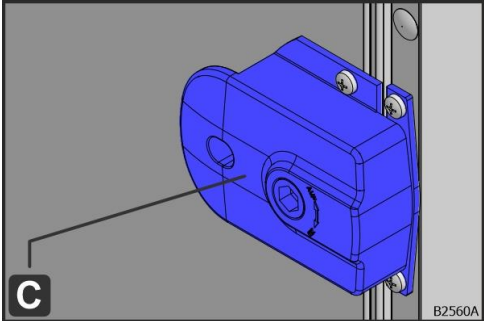

Fig. 9: External lock with key size 10 / double-bit 3



# Filter component

## WARNING



### **Risk of explosion from lack of equipotential bonding**

Non-existent or incorrectly connected equipotential bonding may cause components to become statically charged. The discharge may cause an explosion.

- Connect all factory installed equipotential bonding conductors and secure them to prevent them from loosening.
- Observe the work steps set out in the operating instructions.

## CAUTION



### **Allergic reactions to skin, eyes, or respiratory tract due to contact with filter dust**

Filters may be contaminated with viruses, bacteria, or fungi. During maintenance, cleaning and replacement of the filters, there is a risk of allergic reactions to the skin, eyes or respiratory organs.

- Comply with work instructions.
- Wear protective clothing, gloves, safety glasses, and respiratory protection.
- Avoid contaminating the environment and the new filters.

## Spare filter

Stock at least one set of spare filters. Store in a dry and dust-free environment. Avoid filter contamination and damage. Observe the manufacturer's specifications.

## Inspection

### Maintenance interval

Monthly.

### Work steps

1. Check that all equipotential bonding conductors, earthing straps and earthing screws are tight and secure.
2. Check the connecting elements for corrosion.
3. Replace corroded connecting elements.

### Maintenance interval

Every three months.

### Work steps

- Check the filter for hygienic condition, dirt, odours, damage and corrosion.
- Particle filter: check the differential pressure with a measuring instrument.
- Activated carbon filter: it is usually sufficient to check the filter sensorially for any odours. (To objectively determine the remaining service life and thus use it as a guide value for the inspection interval, the filter manufacturer can carry out a laboratory analysis of the degree of saturation of the activated carbon.) Weighing the filter cartridge is generally not indicative of its service life, as the increase in weight is mostly due to the humidity absorbed.
- Check the filter seat for tightness.
- Perform an electrical safety check of the connection to the equipotential bonding conductor of the AHU see chapter "Electrical safety tests ", page 111.

## Repair

### WARNING



#### **Risk of explosion due to the use of filters with inadequate ignition protection**

Using filters without adequate ignition protection may cause static charging of the AHU. The discharge and the resulting sparks may cause an explosion.

- Use filters that are at least compliant with the ATEX requirements of the AHU.

### Maintenance interval

- Replace filter immediately in case of noticeable contamination, odors, damage, or leakage, when the recommended final resistance or time interval is reached:
  - 1. Filter stage after 12 months at the latest
  - 2. Filter stage after 24 months at the latest

Premature filter replacement may also be necessary if construction or conversion work causes a significant filter load, or if this is indicated as a result of a hygiene inspection.

Replacement of individual filter elements is only permitted in the event of damage to individual elements, provided that the last replacement was not more than 6 months ago.

### Final pressure loss

#### **Recommended final pressure loss for ISO 16890 filters**

<b>Filter class</b>	<b>Recommended final pressure loss (lower value)</b>
ISO coarse	50 Pa + initial pressure loss or 3 x initial pressure loss
ISO ePM1, ISO ePM2.5, ISO ePM10	100 Pa + initial pressure loss or 3 x initial pressure loss

Table 1: Final pressure loss for ISO 16890 filters

#### **Recommended final pressure loss for EN 779 filters**

<b>Filter class</b>	<b>Recommended final pressure loss</b>
G1 - G4	150 Pa
M5 - M6, F7	200 Pa
F8 - F9	300 Pa
E10 - E12, H13	500 Pa

Table 2: Final pressure loss for EN 779 filters

## Work steps

1. Fasten the filter in the filter mounting frame with 4 filter clamps (B) each or hand-tighten the bayonet catch.
2. Do not clamp or damage the filter.
3. Check that the filter is fitted airtight in the filter mounting frame.

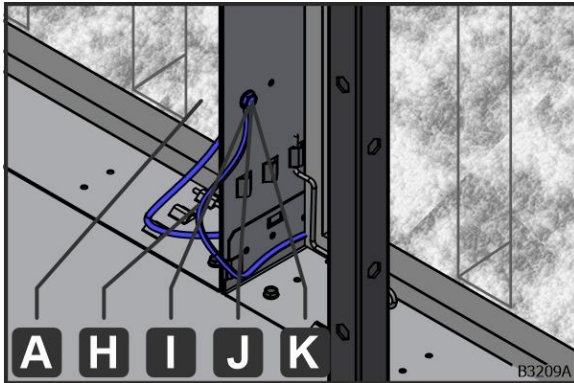

4. Run the pre-assembled equipotential bonding conductors (H) of the filters (A) to the borehole of the filter mounting frame.
5. Use the self-tapping screw (I) to connect the two equipotential bonding conductors (H) through the borehole in the filter mounting frame.
6. Place the toothed lock washer (J) on the self-tapping screw (I).
7. Screw the self locking nut (K) firmly onto the self tapping screw (I).

Fig. 10: filter wall with equipotential bonding

- The filter (A) is connected to the filter mounting frame and the AHU by means of the equipotential bonding conductor (H).
8. Check the connecting elements for corrosion.
  9. Replace corroded connecting elements.
- Perform an electrical safety check of the connection to the equipotential bonding conductor of the AHU see chapter "Electrical safety tests ", page 111.

## HEPA filter installation according to EN 1822

### General procedure

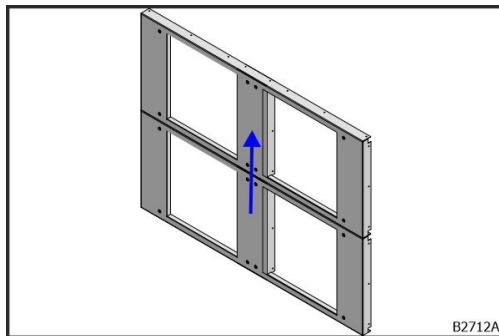

Fig. 11: Assembly sequence

- Start with the bottom row. Work from the bottom up.

### HEPA filter installation work steps according to EN 1822

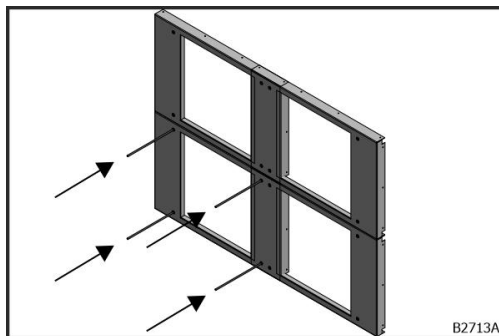

Fig. 12: installing the threaded rods

1. Screw 4 x threaded rod (E) in the rivet nut (F) 8–10 mm deep.

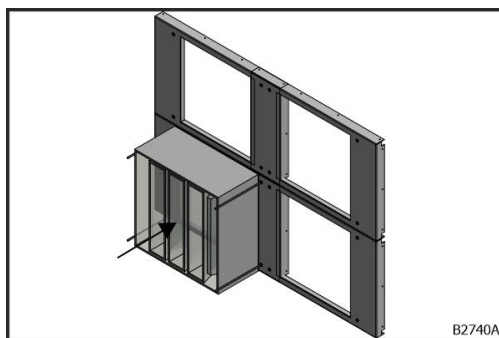

Fig. 13: placing the filter

2. Place the filter (A) between the threaded rods (E).

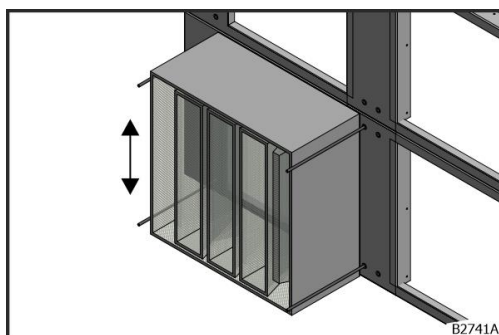
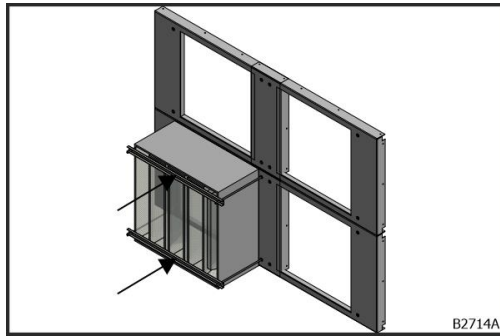

Fig. 14: aligning the filter

3. Align the filter (A) so that the lower edge of the filter finishes 1 mm above the lower edge of the filter wall (G).



4. Slide 2 x clamping section (B) onto the threaded rods (E).

Fig. 15: sliding on clamping sections

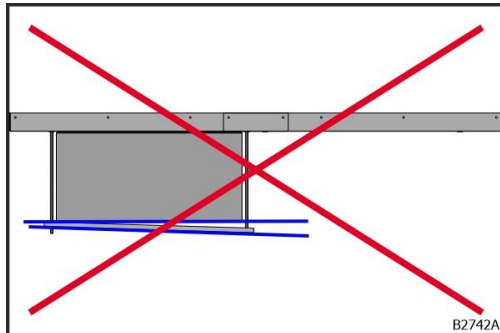

5. Align the clamping sections (B) parallel to the filter wall (G).

Fig. 16: incorrect alignment of clamping sections

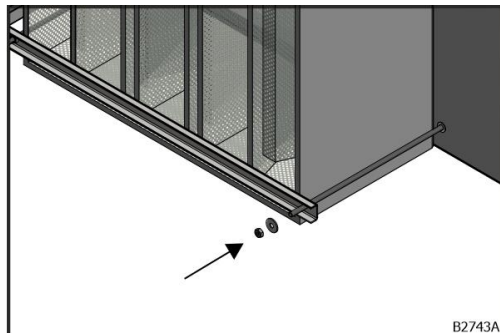

6. Screw 4 x washer (D) and 4 x nut (C) evenly onto the threaded rods (E).

Fig. 17: screwing on the washer and nut

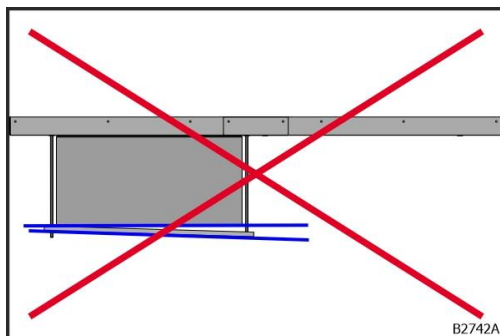

7. Align the clamping sections (B) parallel to the filter wall (G).

Fig. 18: incorrect alignment of clamping sections

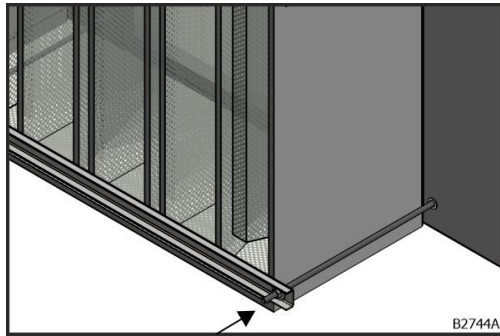

Fig. 19: 2 Nm tightening torque

8. Fasten the nuts (C) with a 2 Nm tightening torque.

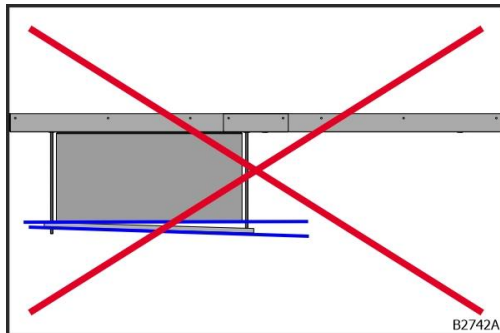

Fig. 20: incorrect alignment of clamping sections

9. Align the clamping sections (B) parallel to the filter wall (G).

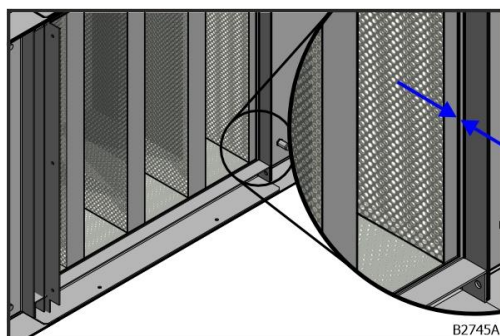

Fig. 21: mounted filter

10. Check for correct assembly: the distance between the filter and filter wall  $2 \pm 0.5$  mm.

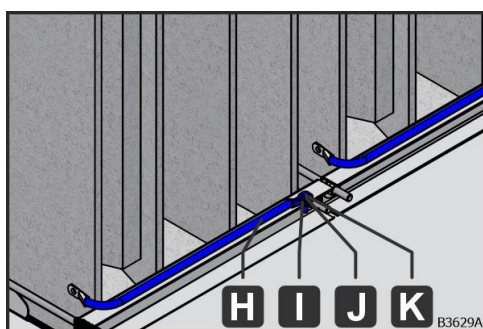

Fig. 22: filter wall with equipotential bonding

11. Route the pre-assembled equipotential bonding conductors (H) of the filters (A) to the borehole of the clamping section (B).
12. Use the self-tapping screw (I) to connect the equipotential bonding conductor (H) through the borehole in the clamping section (B).
13. Place the toothed lock washer (J) on the self-tapping screw (I).

14. Screw the self locking nut (K) firmly onto the self tapping screw (I).
- The filter (A) is connected to the clamping section (B) and the AHU by means of the equipotential bonding conductor (H).

Carry out the work steps for the next filters until all filters have been mounted.

15. Check the connecting elements for corrosion.

16. Replace corroded connecting elements.
  - Perform an electrical safety check of the connection to the equipotential bonding conductor of the AHU see chapter "Electrical safety tests ", page 111.



# Silencer

## WARNING



### **Risk of explosion due to the splitters being installed with an inadequate connection to the equipotential bonding of the AHU**

If the splitters are not adequately connected to the AHU floor, the splitters may become statically charged. The discharge and the resulting sparks may cause an explosion.

- Lay the splitters on a clean unit floor to establish equipotential bonding with the AHU.

## CAUTION



### **Allergic reactions to skin, eyes, or respiratory tract due to contact with splitters**

Splitters may be contaminated with viruses, bacteria, or fungi. During maintenance and cleaning of the silencers, there is a risk of allergic reactions to the skin, eyes or respiratory organs.

- Comply with work instructions.
- Wear protective clothing, gloves, safety glasses, and respiratory protection.
- Avoid contaminating the environment.

## Inspection

### Maintenance interval

Every three months.

### Work steps

- Check splitters for hygienic condition, contamination, damage, and corrosion.
- Perform an electrical safety check of the connection to the equipotential bonding conductor of the AHU see chapter "Electrical safety tests ", page 111.

## Cleaning

### WARNING



#### **Risk of explosion from electrostatic discharge**

Cleaning the AHU with a dry cloth may cause a static charge. The discharge and the resulting sparks may cause an explosion.

- Only wipe the AHU with a damp cloth.
- Follow the instructions in the operating instructions.

### Maintenance interval

Every three months.

### Work steps

- Clean splitters using an industrial vacuum cleaner.

## Repair

### WARNING



#### **Risk of explosion from electrostatic discharge**

Cleaning the AHU with a dry cloth may cause a static charge. The discharge and the resulting sparks may cause an explosion.

- Only wipe the AHU with a damp cloth.
- Follow the instructions in the operating instructions.

- Repair splitters with the repair kit and remove corrosion; if necessary, take a test sample.

Replacing the splitters:

1. Clean soiled surfaces (unit floor and unit frame) with a damp cloth, as the position of the silencers on the unit floor or the unit frame provides a conductive connection and ensures that the component is included in the equipotential bonding of the unit.
  2. Check the connecting elements for corrosion.
  3. Replace corroded connecting elements.
- Perform an electrical safety check of the connection to the equipotential bonding conductor of the AHU see chapter "Electrical safety tests ", page 111.

# Fan

## WARNING



### **Risk of injury due to impeller rotation despite the fan being switched off**

Risk of injury due to impeller rotation as a result of air movement caused by thermal conditions despite of the fan being switched off.

- Avoid backflows from the building (e.g., by closing the dampers).

## WARNING



### **Risk of explosion from lack of equipotential bonding**

Non-existent or incorrectly connected equipotential bonding may cause components to become statically charged. The discharge may cause an explosion.

- Connect all factory installed equipotential bonding conductors and secure them to prevent them from loosening.
- Observe the work steps set out in the operating instructions.

## NOTE



### **Property damage due to foreign objects**

Foreign objects (e.g., tools, small parts) in the AHU or in the duct system can be carried away and cause damage to the fan, the AHU, the duct system, or in the rooms.

- Before switching on the fan, turn the impeller by hand to check if it can run unobstructed.
- Before switching on the fan, check the AHU and the duct system for foreign objects and remove them.

## Inspection

### Maintenance interval

Monthly.

### Work steps

Examine the earthing strap and equipotential bonding conductor of the fan:

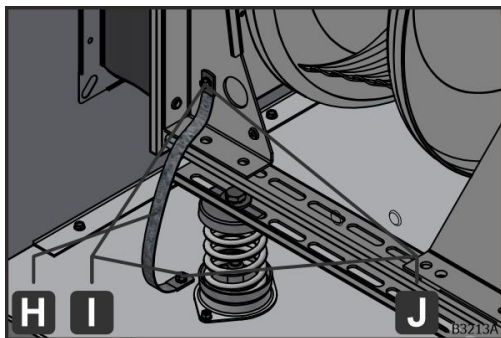

Fig. 23: earthing strap for the unit floor

The support structure of the fan is connected to the AHU equipotential bonding by an earthing strap (H) for the unit floor.

- Check that the earthing strap (H) is tight and secure.
- Check that the screws (I) are tight and secure.
- Check that there are toothed lock washers (J).
- Check the connecting elements for corrosion.
- Replace corroded connecting elements.

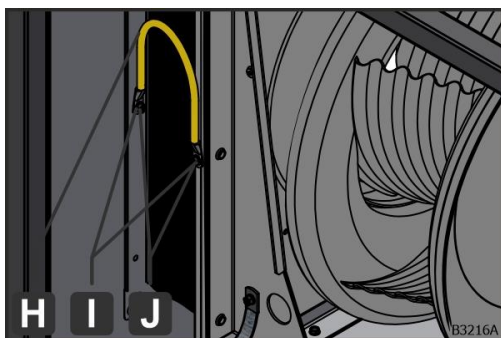

Fig. 24: equipotential bonding conductor for the flexible connection

The support structure of the fan is connected to the AHU equipotential bonding by an equipotential bonding conductor for the flexible connection.

- Check that the equipotential bonding conductor (H) is tight and secure.
- Check that the screws (I) are tight and secure.
- Check that there are toothed lock washers (J).
- Check the connecting elements for corrosion.
- Replace corroded connecting elements.

## Maintenance interval

Every three months.

In case of multi-shift operation and/or special operating conditions such as medium temperature > 40 °C, dust accumulation, etc., the interval must be shortened accordingly.

## Work steps

### WARNING



#### **Risk of explosion from electrostatic discharge**

Cleaning the AHU with a dry cloth may cause a static charge. The discharge and the resulting sparks may cause an explosion.

- Only wipe the AHU with a damp cloth.
  - Follow the instructions in the operating instructions.
- 
- Check the fan for hygienic condition, dirt, damage, corrosion and fastening.
  - Check bearings for noise, vibrations and heating.
  - Check the flexible connection for tightness.
  - Check the function of the vibration damper.
  - Check safety devices for damage, fastening and function.
  - Check the function of the swirl controller.
  - Check the function of the drainage.
  - Remove any dirt from flexible connectors with an industrial vacuum cleaner and wipe with a damp cloth and cleaning agent with a pH value between 7 and 9.
  - Perform an electrical safety check of the connection to the equipotential bonding conductor of the AHU see chapter "Electrical safety tests ", page 111.

## Impeller

- Check impeller for imbalance and vibration; rebalance if necessary.
- Check gap distance for plug fans; correct if necessary.

**Motor**

- Check motor for smooth running, heat, and direction of rotation.
- Clean motor; remove damage and corrosion.
- Measure voltage, current consumption, and phase symmetry.
- Check clamps in terminal board for tight fit; tighten if necessary.
- Check equipotential bonding; retighten or replace if necessary.
- Check cable guides (e.g., cable duct) for contamination and, if necessary, clean them with an industrial vacuum cleaner and wipe them with a cloth and a cleaning agent with a pH value between 7 and 9.

## **Fan with housing**

### **Belt drive**

- Check belt drive for wear, tension, alignment of motor and fan pulley (tolerance  $< 0.4^\circ$ ; i.e.  $< 7$  mm/m), function, and mount (see tightening torques).

### **Drive clutch**

- Observe the manufacturer's specifications.
- Check the temperature.



## Repair

### WARNING



#### **Risk of explosion due to the use of fans with inadequate ignition protection**

Using fans without adequate ignition protection may cause static charging of the AHU. The discharge and the resulting sparks may cause an explosion.

- Use fans (fully assembled fan unit comprising motor, impeller, nozzle, flexible connection and support structure) that as a minimum fulfil the ATEX requirements of the AHU.

- Replace bearings (at the latest at the end of the theoretical service life).
- Lubricate the bearing. Observe manufacturer's instructions.
- Clean fan, remove damage and corrosion, tighten mounting parts.

### Motor

Only use suitable and authorised load handling attachments when removing the motor. Ensure sufficient AHU stability, e.g. by fixing it to the foundation.

The following options are available from robatherm for removing the motor:

- Motor removal device see chapter "Motor removal device", page 35
- Motor removal device with lift out device see chapter "Motor removal device with lift out device", page 51
- Motor extraction device

### Fan with housing

#### **Belt drive**

- Replace belt set
- Set alignment of motor and fan pulley
- Readjust belt tension
- Clean belt drive

If one or more V-belts fail in a multi-groove drive, a new set of V-belts must be fitted. Before V-belt installation, reduce the center distance so that the belt can be placed in the grooves without forcing. Forcible assembly by means of a screwdriver, etc. is not permitted in any case, as this will result in damage.

Before commissioning, check V-belt drive and adjust if necessary:

- Fastening screws of bushings and hubs (see tightening torques).
- Belt tension (see chapter on belt tension).
- Alignment of belt pulleys (tolerance  $< 0.4^\circ$ ; i.e.  $< 7$  mm/m).

After a run-in period of 1 to 2 hours, check the V-belt drive and adjust if necessary:

- Fastening screws of bushings and hubs (see tightening torques).
- Belt tension (see chapter on belt tension).
- Alignment of belt pulleys (tolerance  $< 0.4^\circ$ ; i.e.  $< 7$  mm/m).

The belt tension must be checked or adjusted according to the manufacturer's specifications using a suitable measuring device (e.g., belt tension gauge). Observe the operating instructions of the measuring device.

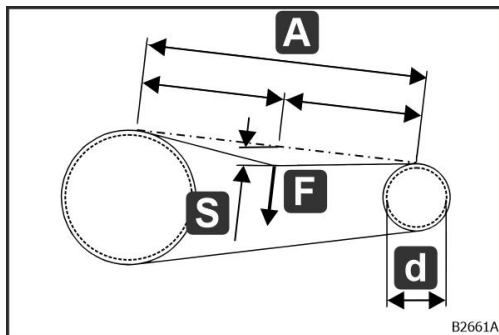

Fig. 25: Belt tension for the fan with housing

1. Measure the center distance (A) of the pulleys [m].
2. Multiply the center distance (A) by 16.
- The product is the belt deflection (S) [mm].
3. Apply force (F) to the belt in the middle of the center distance (A) so that the calculated belt deflection (S) is achieved.
4. Measure deflection force (F) [N].
5. Compare the deflection force (F) with the value on the nameplate (test force  $F_P$ ).

After a run-in period of 1 to 2 hours, check the V-belt drive and adjust if necessary.

The belt drive is largely maintenance-free after the run-in phase. However, depending on the installation site and operating mode, it is recommended to check the belt tension regularly.

#### Drive clutch

- Observe the manufacturer's specifications.
- Change oil.
- Clean the drive coupling.
- Perform an electrical safety check of the connection to the equipotential bonding conductor of the AHU see chapter "Electrical safety tests ", page 111.

## Motor removal device

### Proper use

The motor removal device is suitable for the removal and installation of electric motors and smaller complete fan units within AHUs weighing up to 800 kg. Corner nodes are installed in the relevant casings. The motor removal device is suitable for temperatures from -20 °C to +40 °C. The motor removal device is designed for 10 load cycles.

### Foreseeable misuse

#### WARNING



#### Danger from misuse

Serious personal injury or even death and damage to property can be caused by misuse of the motor removal device.

The motor removal device may only be used in conjunction with the corner nodes. Any other use, in particular attaching the lever hoists to other fastening points on the casing, is not permitted.

Only use lever hoists with a maximum load capacity of 3000 kg.

The load to be moved may have a maximum weight of 800 kg.

The motor removal device must not be exposed to aggressive media.

The motor removal device must not be used in environments with a potentially explosive atmosphere (e.g. conductive dusts, explosive gases).

### Personnel qualification

The work described in this section may only be performed if the person has the following qualifications:

- Mechanic

### Space requirements

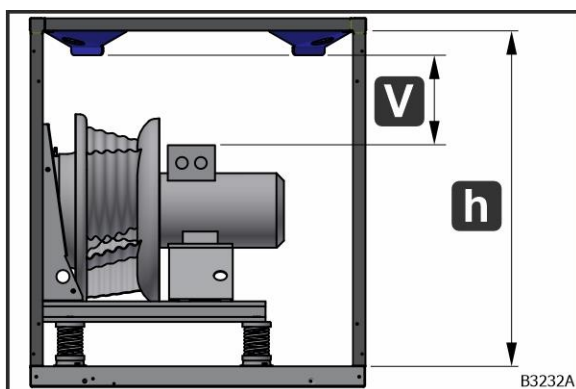

A minimum height  $V$  of 400 mm is required between the upper edge of the load to be suspended and the installation level of the corner nodes; this height must not be lower than this during use.

Fig. 26: minimum height  $V$

## Set-up and function

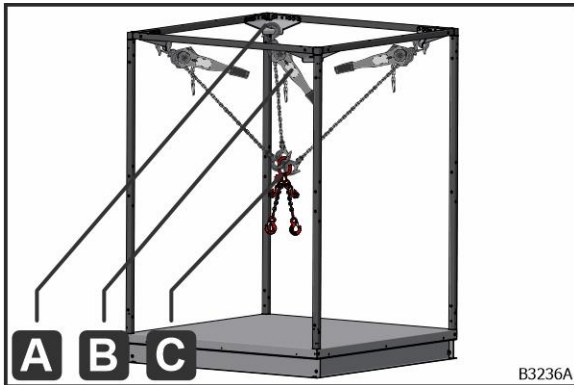

Fig. 27: motor removal device structure

The motor removal device comprises

- 4 corner nodes (A),
- 3 lever chain hoists (B) and
- 1 sling chain (C).

The 4 corner nodes (A) were factory installed in the upper corners of the casing. 3 lever chain hoists (B) are hooked into 3 (of these 4) corner nodes (A). Depending on the number of anchorage eyelets, 1 or 2 hooks of the sling chain (C) are hooked into the existing anchorage eyelets of the load (e.g. electric motor). The 3 hooks of the lever chain hoists (B) are hooked into the ring eye of the sling chain (C).

The load can be moved to any position in the casing by actuating the lever chain hoists (B) alternately and/or simultaneously in the correct sequence and pulling direction.

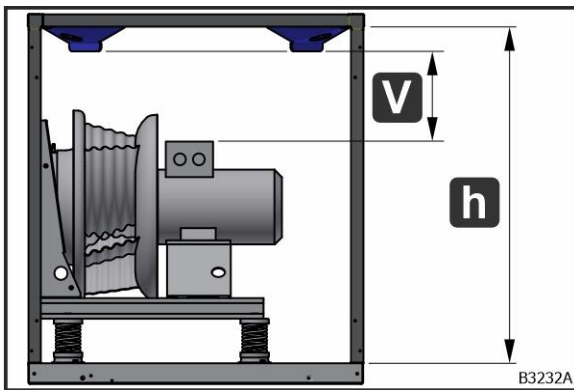

Fig. 28: minimum distance (V) between corner nodes and load.

The lifting height is limited by the tractive force of the lever chain hoists (B) (the load capacity is set via a slipping clutch). This limit is reached at a minimum distance (V) of approx. 400 mm between the installation level of the corner nodes (A) and the upper edge of the load to be suspended.

The height by which the load can be lowered is limited by the length of the chains of the lever chain hoists (B). This height can be increased by (temporarily) lowering the load and extending the sling chains (C) using the shortening hooks (or by attaching additional sling chains with a corresponding load capacity).

## Components

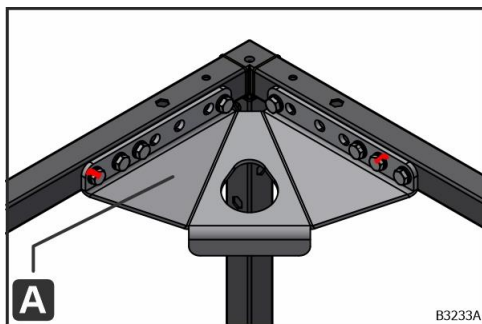

Fig. 29: A – corner nodes

The corner nodes (A) transfer the tractive force into the casing frame.

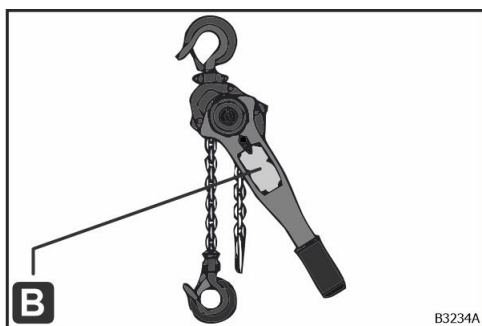

Fig. 30: B – lever chain hoist

The lever chain hoists (B) provide the required tractive force.

Model	Load capacity [kg]	Weight [kg]
DD-LB 075	750	9.5
DD-LB 150	1500	13
DD-LB 150	3000	29

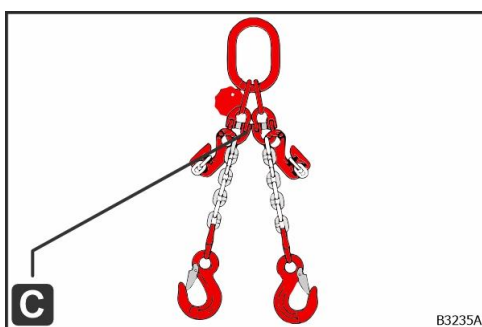

Fig. 31: C – sling chain

For selecting the right lever chain hoist see chapter "Selecting the lever chain hoist", page 39.

A 2-leg sling chain (C) is used to attach the load. This also includes a chain shortening hook.

Weight: 3.9 kg

### Lever chain hoist

The lever chain hoists are a central operating element of the motor removal device. For a detailed description of the function and operation, see the appendix "Dolezych – DoLast hoists – original operating instructions – DD lever hoist", "Operation" section.

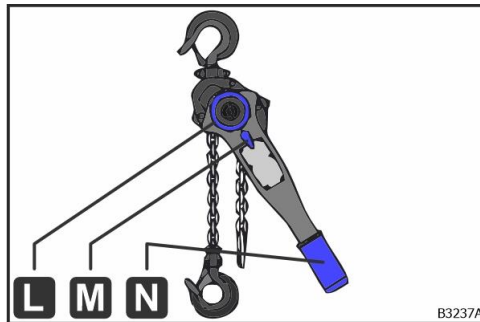

- L – handwheel
- M – changeover lever
- N – hand lever

Fig. 32: Part designation of the lever chain hoist from the manufacturer Dolezych

### Selecting the lever chain hoist

The correct lever chain hoists can be determined using the following table, depending on the size of the fan, the motor weight and the installation height.

<b>Fan (with AC motor)</b>	<b>Max. motor weight</b>	<b>Minimum dimension height h</b>	<b>Lever chain hoist (nominal load capacity)</b>	<b>Minimum dimension height h</b>	<b>Lever chain hoist (nominal load capacity)</b>
Fan size	[kg]	[mm]	[kg]	[mm]	[kg]
280	30	1224	750	-	-
315	40	1224	750	-	-
355	40	1224	750	-	-
400	65	1224	750	-	-
450	65	1224	750	-	-
500	142	1224	750	-	-
560	142	1224	1500	1530	750
630	142	1224	1500	1530	750
710	142	1428	750	-	-
800	210	1530	750	-	-
900	284	1530	1500	1836	750
1000	373	1632	1500	2142	750
1120	373	1836	1500	2142	750

Table 3: Selection of the lever chain hoist depending on the size of the fan, motor weight and installation dimension height

## Bearing

The following storage conditions must be observed for the motor removal device:

- Do not store outdoors.
- Store in a dry and dust-free environment.
- Do not expose to aggressive media.
- Observe a storage temperature of -20 °C to +40 °C.

## Commissioning

### Commissioning requirements

The condition of the corner nodes (A), the lever hoists (B) and the sling chains (C) must be checked:

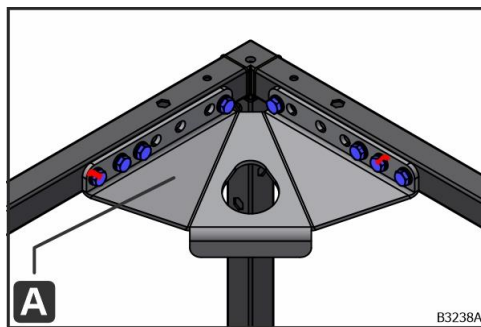

Fig. 33: Fastening the corner nodes

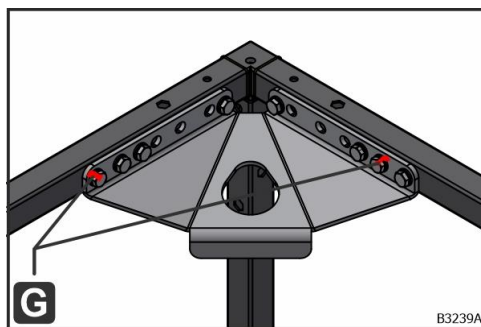

Fig. 34: G – screw locking lacquer

For rectification of faults see chapter "Fault", page 50.

- Visually inspect all parts for cracks, corrosion and/or deformation. If there are any abnormalities, the motor removal device must not be put into operation.
- Check the fastening of the corner nodes (A). Each corner node (A) must be secured with 8 screws. If incomplete, the motor removal device must not be put into operation.
- Carry out a visual inspection of the screw locking lacquer (G) on the corner nodes (A). If there is any damage, the motor removal device must not be put into operation.

## Operation

### Impeller suspension for AC motors

For fans with AC motors, the impeller must be taken off before removing the motor see chapter "Impeller suspension for AC motors", page 47.



## Attaching the sling chains

### NOTICE



#### Material damage due to wrongly attached load

The anchorage eyelets of the load are not designed for oblique pull.

- Use the sling chain to attach the load.

The sling chains (B) are attached to the existing anchorage eyelets of the load (e.g. electric motor) with one or two hooks.

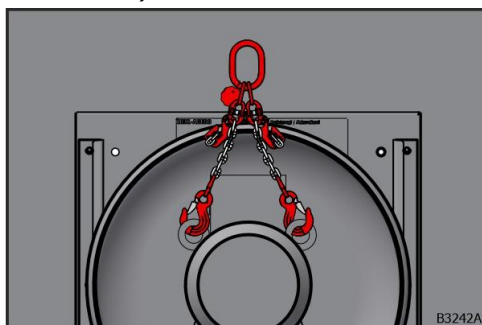

Fig. 35: attaching the sling chains to two anchorage eyelets

- Hook the sling chains into the existing anchorage eyelets of the load (e.g. electric motor).

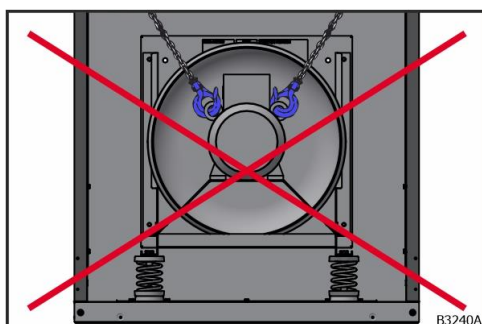

Fig. 36: Load attached wrongly

By using chain shortening hooks, the length of the sling chains (B) can be adjusted to the requirements of the specific situation.

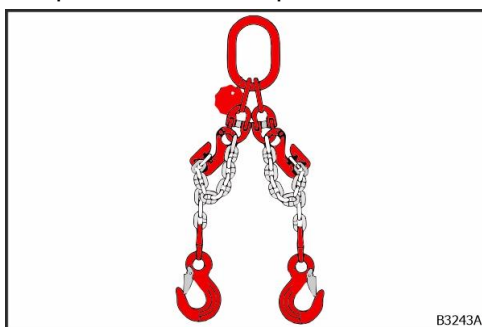
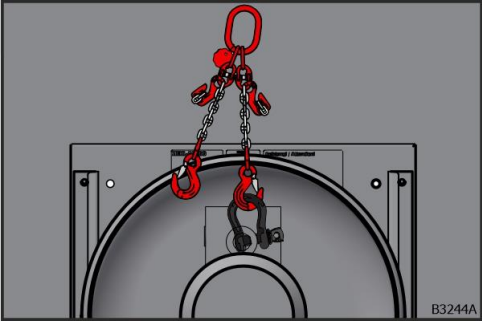

Fig. 37: using the chain shortening hooks

- The sling chains (B) can be shortened to a minimum using chain shortening hooks.



- With an anchorage eyelet, a shackle can be inserted into the centre of it.

Fig. 38: attaching the sling chains to an anchorage eyelet

### Determining the 3 corner nodes for attaching the lever chain hoists

The load is statically suspended from 3 lever chain hoists. As the lever chain hoists can only be loaded in tension due to the chains as the means of traction, the lever chain hoists must always be arranged in a star shape (when viewed from above). None of the chains may form an angle of more than  $180^\circ$  to the neighbouring chain.

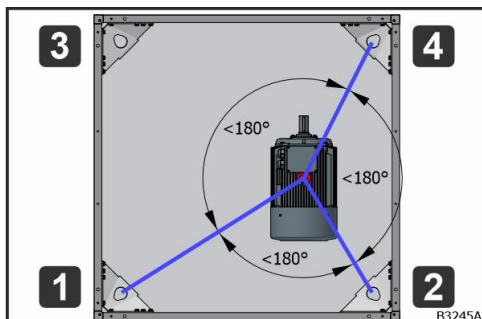

Fig. 39: correct use of corner nodes 1, 2 and 3

- Using corner nodes 1, 2 and 4: all angles are less than  $180^\circ$ .

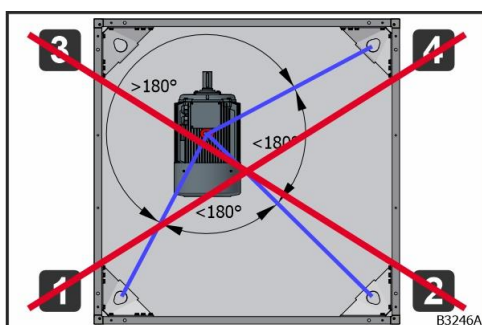

Fig. 40: wrong use of corner nodes 1, 2 and 3

- Using corner nodes 1, 2 and 4: one angle is greater than  $180^\circ$ . The load must not be lifted, as it may swing uncontrollably in the direction of corner node 2.
- Unhook lever chain hoist from corner node 2 and reattach at corner node 3.

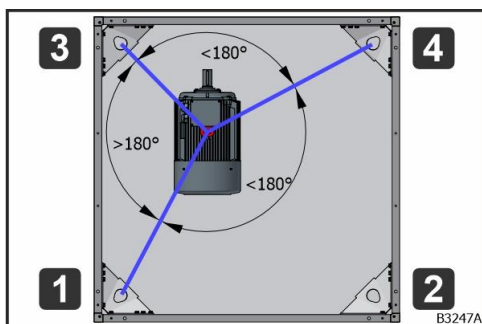

Fig. 41: correct use of corner nodes 1, 3 and 4

- Using corner nodes 1, 3 and 4: all angles are less than  $180^\circ$ .

## Adjusting the length of the lever chain hoists

### WARNING



#### Risk of injury from falling or swinging load

If the changeover lever of the lever chain hoist is set to the freewheel position "N" when the load is below the minimum load, the load may move in an uncontrolled manner. This may result in injury due to the load swinging or falling.

- No lifting and clamping operations when the changeover lever is in the freewheel position "N".
- Do not select freewheel position "N" when loaded.

The chain is set to the correct length with the freewheel of the lever chain hoist.

#### Requirement

- No load is attached to the lever chain hoist.
- The lever chain hoist is not under tension.

#### Work steps

1. Set the changeover lever (M) to freewheel position "N".
2. Turn the handwheel (L) anti-clockwise until it locks.  
→ The brake is released.
3. Pull the chain into the required position.  
→ The chain is set to the correct length.

## Tightening the lever chain hoists to lift the load

### TIP



#### Lever chain hoist braking mechanism

The braking mechanism is only activated in the "UP" position by applying the following minimum loads:

- DD-LB 075 35daN
- DD-LB 150 38daN
- DD-LB 300 50daN

#### Requirement

- Ensure that there are no persons or blocking parts in the immediate movement area of the load.

#### Work steps

1. Set the changeover lever (M) to the "UP" position.
  2. Turn the handwheel (L) clockwise to tension the chain.
  3. Turn the hand lever (N) clockwise to lift the load.
- The load is lifted.

## Releasing the lever chain hoists and lowering the load

#### Requirement

- Ensure that there are no persons or blocking parts in the immediate movement area of the load.

#### Work steps

- Set the changeover lever (M) to the "DN" (down) position.
  - Turn the hand lever (N) anti-clockwise to slowly lower the load.
- The load is lowered.

### Moving the load diagonally

The following steps are required to move the load from one corner to the diagonally opposite corner (e.g. from corner node 4 to corner node 2):

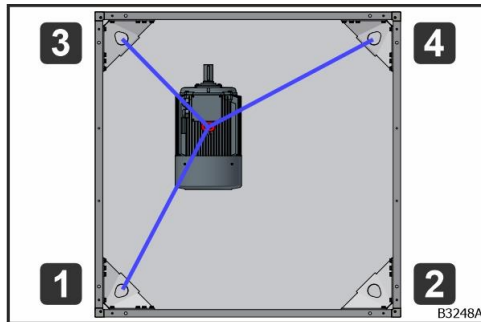

Fig. 42: load with corner node 4

1. Tighten all 3 lever chain hoists.
  2. Tighten lever chain hoists 1 and 4 further and loosen lever chain hoist 3.
- The load moves towards the casing centre.

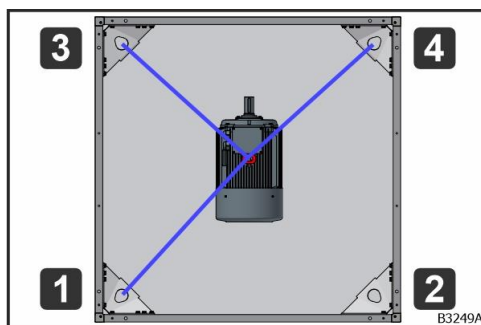

Fig. 43: load in centre of casing with lever chain hoist in corner node 4

Chains of lever chain hoist 1 and 4 are in line.

3. Release lever chain hoist 3.
4. Detach lever chain hoist from corner node 3.

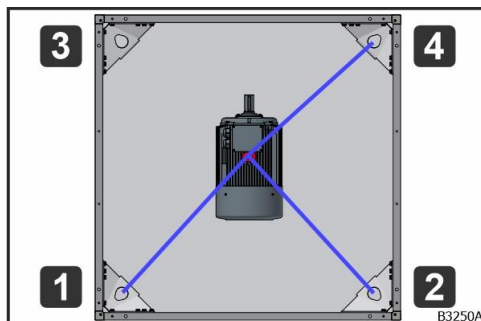

Fig. 44: load in centre of casing with lever chain hoist in corner node 2

Chains of lever chain hoist 1 and 4 are in line.

5. Attach lever chain hoist to corner node 2.

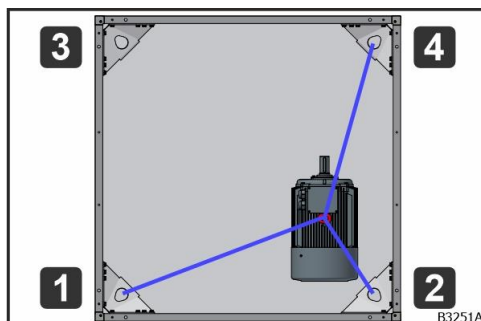

Fig. 45: load moves towards corner node 2

6. Release the chains of lever chain hoists 1 and 4 and tighten lever chain hoist 2.
- The load moves towards corner node 2.

## Impeller suspension for AC motors

For fans with AC motors, the impeller must be taken off before removing the motor.

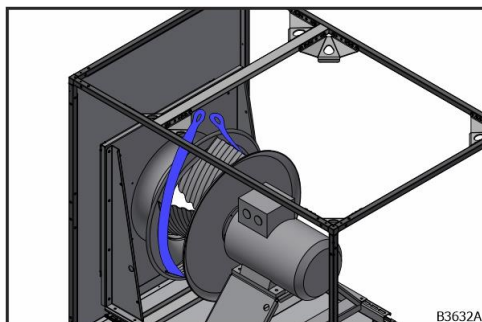

Fig. 46: Impeller with polyester sling

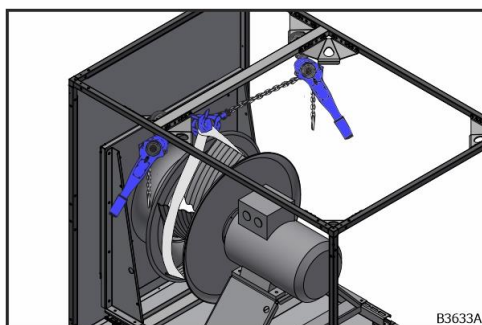

Fig. 47: Lever chain hoists in the corner brackets

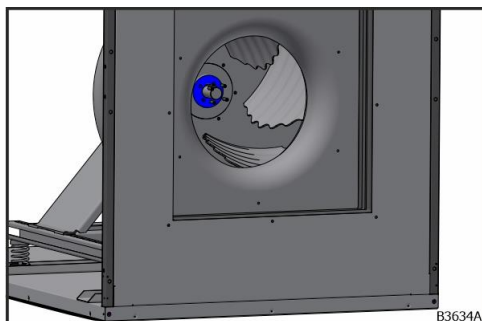

Fig. 48: Impeller bushing

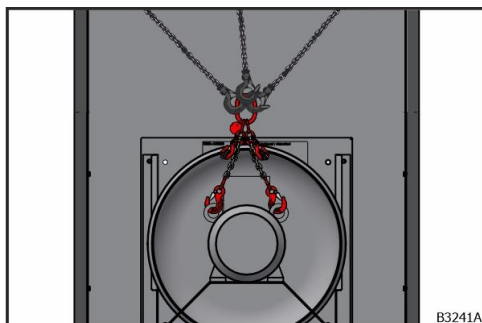

Fig. 49: Suspended motor

1. Lay the polyester sling round the impeller.
2. Attach the polyester sling to two corner brackets above the impeller using shackles in two lever chain hoists.
3. Pull the lever chain hoists until there is a slight tension see chapter "Adjusting the length of the lever chain hoists", page 44, see chapter "Tightening the lever chain hoists to lift the load", page 45 and see chapter "Releasing the lever chain hoists and lowering the load", page 45.
4. Detach the impeller bushing from the intake side.
5. Attach the sling chains to the existing anchorage eyelets of the AC motor see chapter "Determining the 3 corner nodes for attaching the lever chain hoists", page 43.
6. Attach the load hook of the lever chain hoists to the lug of the sling chain see chapter "Attaching the sling chains", page 41.

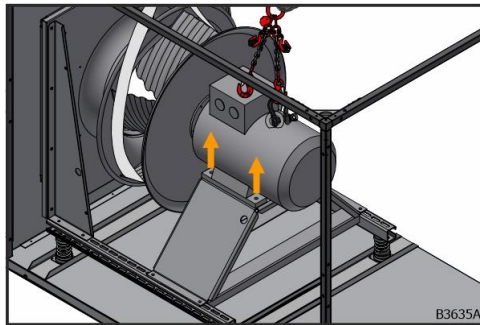

Fig. 50: Motor mount screws

7. Remove the screws attaching the motor to the motor mount.

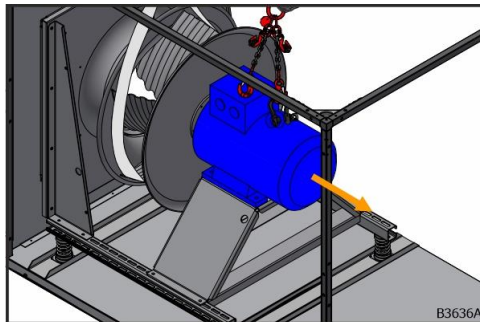

Fig. 51: Pulling out the motor

8. Pull the motor with drive shaft out of the impeller.  
→ The motor can now be removed see chapter "Moving the load diagonally", page 46.



## Maintenance

### Maintenance interval

Every year.

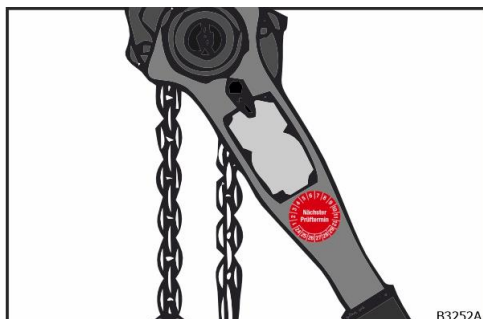

Fig. 52: inspection sticker (lever chain hoist)

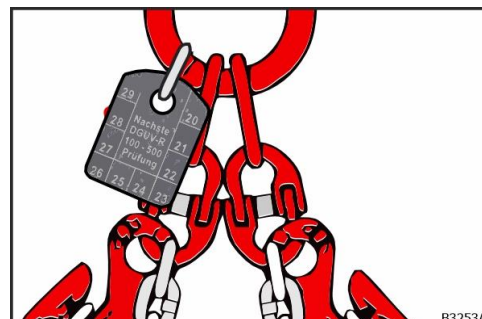

Fig. 53: inspection mark (sling chain)

The inspection sticker or inspection mark indicates the next required inspection.

### Inspection

The condition of the corner nodes (A), the lever hoists (B) and the sling chains (C) must be checked:

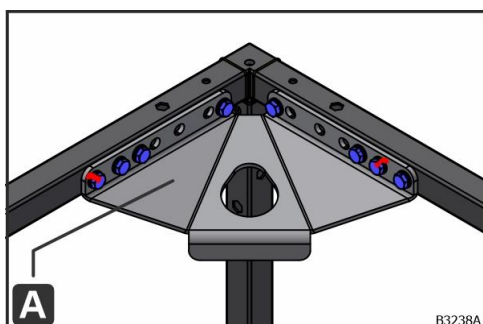

Fig. 54: Fastening the corner nodes

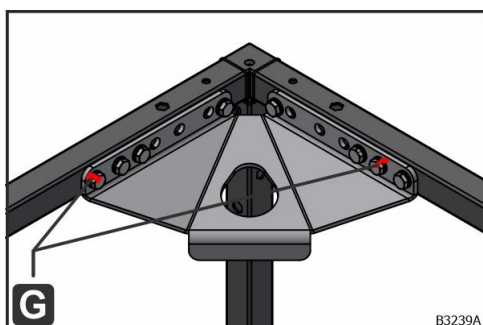

Fig. 55: G – screw locking lacquer

For rectification of faults see chapter "Fault", page 50.

- Visually inspect all parts for cracks, corrosion and/or deformation. If there are any abnormalities, the motor removal device must not be put into operation.
- Check the fastening of the corner nodes (A). Each corner node (A) must be secured with 8 screws. If incomplete, the motor removal device must not be put into operation.
- Carry out a visual inspection of the screw locking lacquer (G) on the corner nodes (A). If there is any damage, the motor removal device must not be put into operation.

## **Fault**

### **Defective parts**

In the event of any faults or defective parts in the motor removal device, these must be rectified by appropriately trained personnel.

- Do not bend any bent parts back into shape. Replace bent parts with original spare parts.
- Do not weld cracked parts. Replace cracked parts with original spare parts.

The disassembly and assembly of the parts must be carried out professionally, taking into account and with an understanding of the function and load of the parts. The work carried out must also be checked and confirmed by qualified personnel.

### **Interrupted screw locking lacquer**

The screw locking lacquer must not be interrupted. Proceed as follows if the screw locking lacquer is interrupted:

1. Have the cause determined by appropriately trained personnel.
2. Tighten the screw with a torque of 20 Nm.
3. Apply screw locking lacquer.

The work carried out must be checked and confirmed by qualified personnel.

## Motor removal device with lift out device

### Proper use

In conjunction with the motor removal device, the lift out device is suitable for removing and installing electric motors and smaller complete fan units weighing up to 400 kg from AHUs. Fasteners are installed in the relevant casings. The lift out device enables the load to be lifted from a position inside the casing to a position outside the casing or vice versa. This is necessary if the load inside the casing cannot be picked up by another industrial truck (e.g. forklift). The lift out device is suitable for temperatures from -20 °C to +40 °C. The lift out device is designed for 10 load cycles.

### Foreseeable misuse

#### WARNING



#### Danger from misuse

Serious personal injury or even death and damage to property can be caused by misuse of the motor removal device.

The motor removal device may only be used in conjunction with the fasteners. Any other use, in particular attaching the lever hoists or the supporting arm to other fastening points on the casing, is not permitted.

Only use lever hoists with a maximum load capacity of 3000 kg.

The load to be moved may have a maximum weight of 400 kg.

The lift out device may only be installed in the appropriate door widths.

The lift out device must not be exposed to aggressive media (e.g....).

The lift out device must not be used in environments with a potentially explosive atmosphere (e.g. conductive dusts, explosive gases).

### Personnel qualification

The work described in this section may only be performed if the person has the following qualifications:

- Mechanic

### Space requirements

The lift out device is installed in inspection doors or behind panels. It must be possible to open the inspection door fully. It must be possible to remove the panel.

## Set-up and function

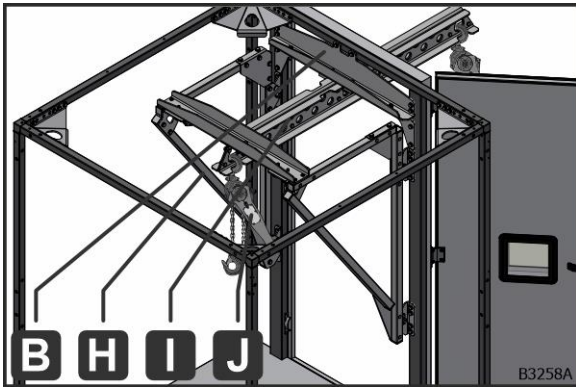

Fig. 56: lift out device mounted

The lift out device comprises factory installed fasteners and attachments that are only fitted on site when the device is used. The factory installed fasteners are already mounted in the corresponding position in the casing. Once all components have been fitted, the lift out device is ready for use.

The supporting arm (I) is fastened centrally in the opening. At the beginning (=inside the casing) and at the end (=outside the casing), there are lifting points in the supporting arm (I) where the corresponding lever hoists (J) can be attached. The mounting section (B) uses the two support struts (H) to brace the bending torque generated when the load is lifted on the casing frame.

The load can be moved from a defined position inside the casing to a defined position outside the casing, or vice versa, by alternately and/or simultaneously actuating the lever chain hoists (J) in the correct sequence and pulling direction. The load can then be set down on the floor. For greater height distances, the third lever chain hoist (J) can be used as an extension for the outer lever chain hoist (J).

## Components

The lift out device comprises factory installed fasteners and attachments that are only fitted on site when the device is used. The factory installed fasteners are already mounted in the corresponding position in the casing.

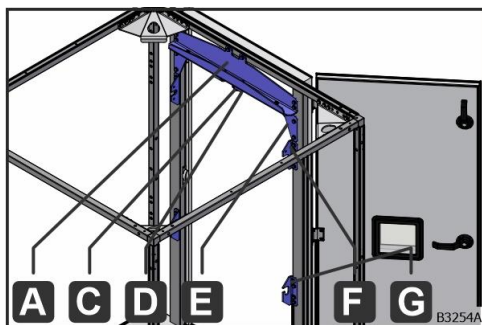

Fig. 57: factory installed fasteners



Fig. 58: parts to be mounted on site

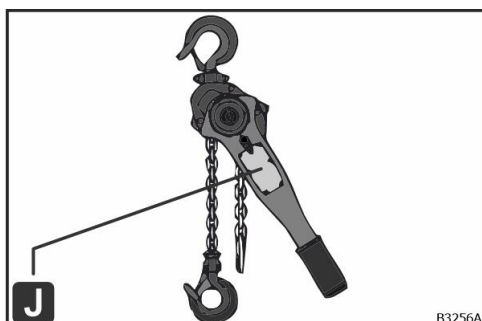

Fig. 59: J – lever chain hoist

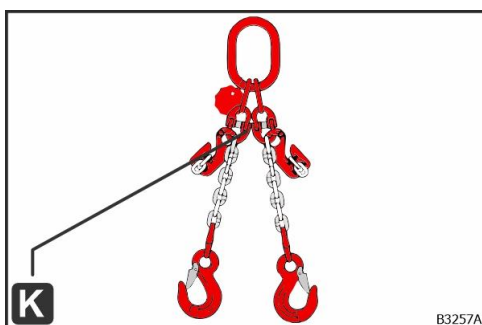

Fig. 60: K – sling chain

A – mounting section

D – guide plate

E – additional bracket right/left

C – C-M10 mini indexing plunger

F – upper suspension bracket right/left

G – lower suspension bracket right/left

B – mounting section

Model	Outer door frame/ panel width [mm]	Weight [kg]
L06	612	4.5
L07.5	765	5.4
L09	918	6.3

H – support strut right/left:

I – supporting arm; weight: 14.1 kg

The lever chain hoists (J) provide the required tractive force.

Model	Load capacity [kg]	Weight [kg]
DD-LB 075	750	9.5
DD-LB 150	1500	13
DD-LB 150	3000	29

For selecting the right lever chain hoist see chapter "Selecting the lever chain hoist", page 55.

A 2-leg sling chain (K) is used to attach the load. This also includes a chain shortening hook.

Weight: 3.9 kg

### Lever chain hoist

The lever chain hoists are a central operating element of the motor removal device. For a detailed description of the function and operation, see the appendix "Dolezych – DoLast hoists – original operating instructions – DD lever hoist", "Operation" section.

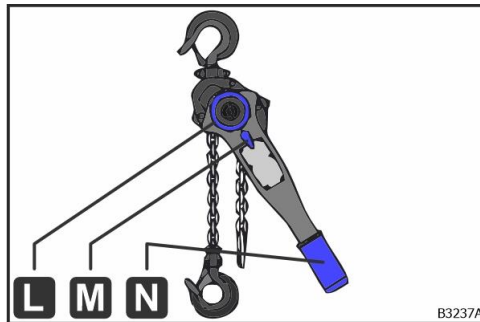

- L – handwheel
- M – changeover lever
- N – hand lever

Fig. 61: Part designation of the lever chain hoist from the manufacturer Dolezych

### Selecting the lever chain hoist

The correct lever chain hoists can be determined using the following table, depending on the size of the fan, the motor weight and the installation height.

Fan (with AC motor)	Max. motor weight	Minimum dimension height h	Lever chain hoist (nominal load capacity)	Minimum dimension height h	Lever chain hoist (nominal load capacity)
Fan size	[kg]	[mm]	[kg]	[mm]	[kg]
280	30	1224	750	-	-
315	40	1224	750	-	-
355	40	1224	750	-	-
400	65	1224	750	-	-
450	65	1224	750	-	-
500	142	1224	750	-	-
560	142	1224	1500	1530	750
630	142	1224	1500	1530	750
710	142	1428	750	-	-
800	210	1530	750	-	-
900	284	1530	1500	1836	750
1000	373	1632	1500	2142	750
1120	373	1836	1500	2142	750

Table 4: Selection of the lever chain hoist depending on the size of the fan, motor weight and installation dimension height

### Bearing

The following storage conditions must be observed for the motor removal device:

- Do not store outdoors.
- Store in a dry and dust-free environment.
- Do not expose to aggressive media.
- Observe a storage temperature of -20 °C to +40 °C.

## Assembly and removal

### Work steps for assembly of parts to be installed on site

#### Requirements

The parts to be installed on site (see chapter "Work steps for assembly of parts to be installed on site", page 56) are available.

#### Work steps for assembling the left-hand support strut (H)

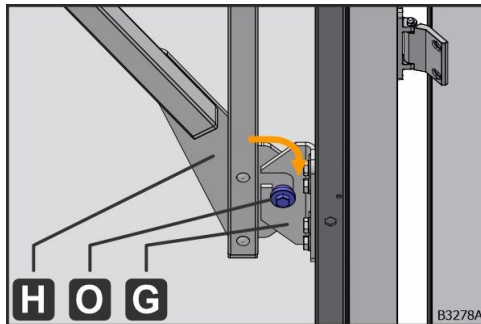

1. Insert the lower centring pin (O) of the support strut (H) into the groove of the lower suspension bracket (G).
2. Push the support strut (H) downwards.

Fig. 62: Inserting the lower centring pin into the groove

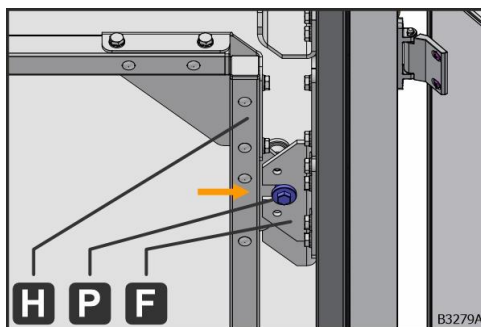

3. Swivel the support strut (H) upwards.
4. Insert the upper centring pin (M) into the groove of the upper suspension bracket (F).

Fig. 63: Inserting the upper centring pin in the groove

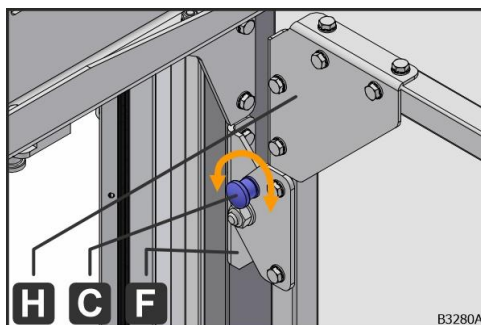

5. Turn the handle of the C-M10 indexing plunger (C) back and forth to lock the C-M10 mini indexing plunger (C) in the opening of the upper suspension bracket (F).
- The left-hand support strut H is now engaged.

Fig. 64: Engaging the mini indexing plunger in the upper suspension bracket

#### Work steps for assembling the right-hand support strut (H)

Carry out steps 1–5 for the right-hand support strut (H).



## Work steps for assembling the mounting section (B)

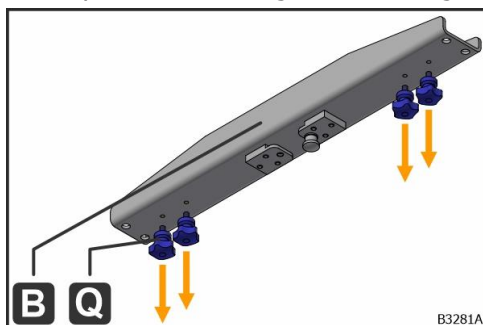

Fig. 65: Removing the M8 star grips

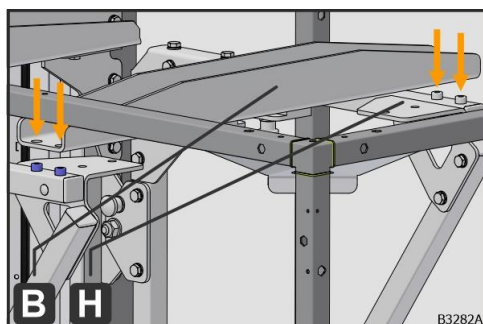

Fig. 66: Placing the mounting section (B)

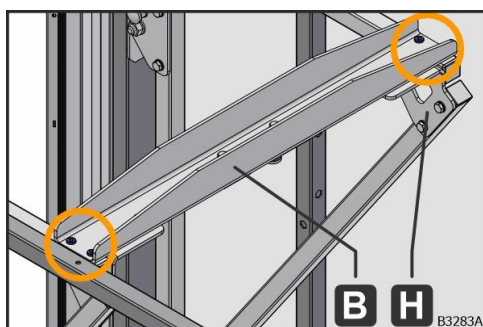

Fig. 67: Centring the cheese head screws

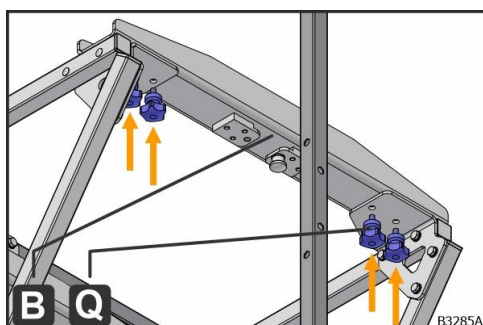

Fig. 68: Screwing on the mounting section (B)

1. Remove 4 x star grips M8 (Q) from the mounting section (B).

2. Place the mounting section (B) on top of the previously installed support struts (H).

→ The side boreholes of the mounting section (B) engage in the screw heads of the cylinder head screws of the support struts (H).

3. Screw the mounting section (B) to the support struts (H) using 2 M8 star grips on each side.
  4. Hand-tighten the M8 star grips.
- The mounting section (B) is now mounted.

Work steps for assembling the supporting arm (I)

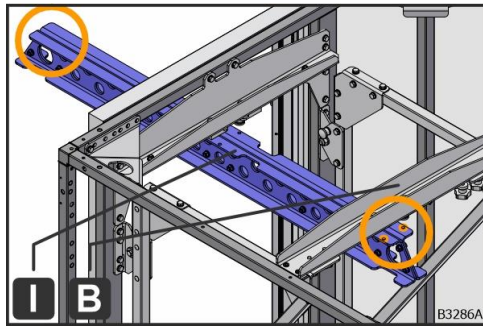

1. The borehole for the mini indexing plunger in the supporting arm (I) must point towards the mounting section (B).

Fig. 69: Borehole in the supporting arm (I)

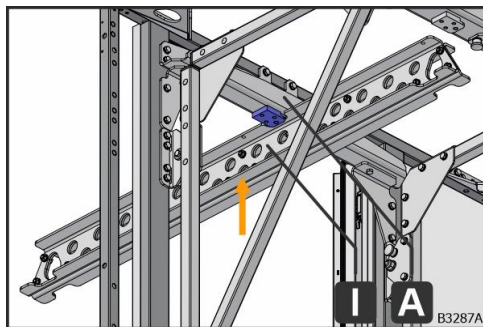

2. Lift the recess of the supporting arm (I) into the front guide plates of the mounting section (A).

Fig. 70: Lifting the supporting arm (I) into the front guide plate

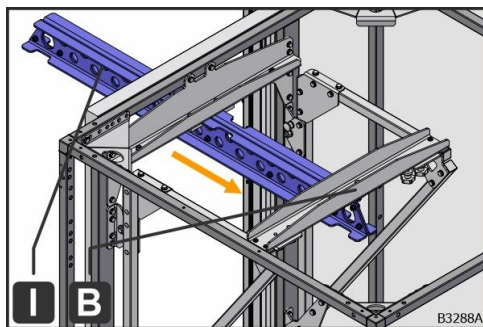

3. Push the supporting arm (I) towards the mounting section (B).

Fig. 71: Sliding in the supporting arm (I)

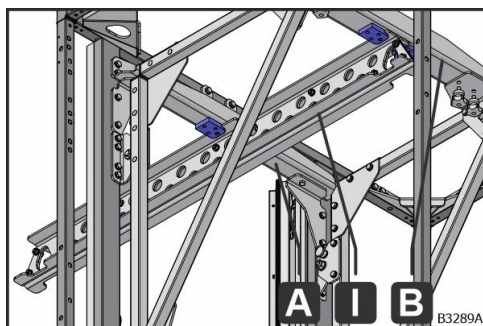

4. Slide the supporting arm (I) into the rear guide plate. Ensure that the supporting arm (I) is pushed into both the front and rear guide plate.

Fig. 72: Inserting the supporting arm (I) into the rear guide plate

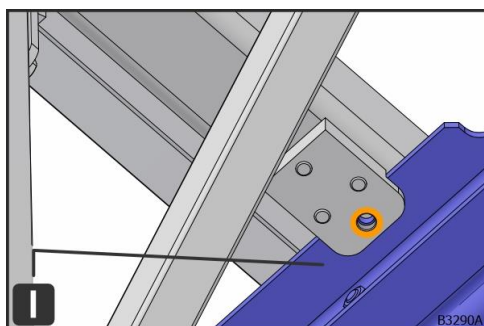

Fig. 73: Positioning the supporting arm for securing with the mini indexing plungers

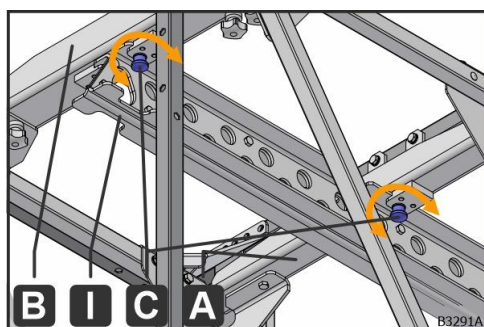

Fig. 74: Securing the supporting arm with mini indexing plungers

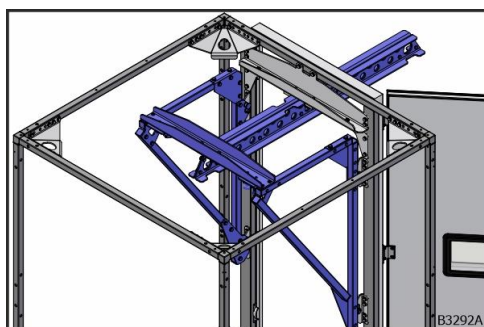

Fig. 75: Installed lift out device

5. Push in the supporting arm (I) until the boreholes of the supporting arm (I) are aligned with the pins of the C-M10 mini indexing plunger (C).

6. Turn the handle of the front C-M10 mini indexing plunger (C) back and forth until it engages in the boreholes of the supporting arm (I).

7. Turn the handle of the rear C-M10 mini indexing plunger (C) back and forth until it engages in the boreholes of the supporting arm (I).

→ The supporting arm (I) is secured.

→ Assembly of the parts to be mounted on site is complete.

### Removal of parts to be installed on site

The on-site parts are removed in the reverse order to installation.

## Commissioning

### Commissioning requirements

The condition of the corner nodes (A), the lever hoists (B) and the sling chains (C) must be checked:

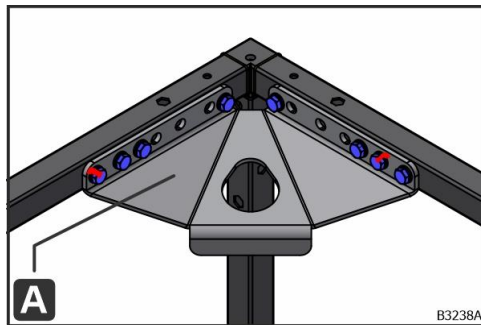

Fig. 76: Fastening the corner nodes

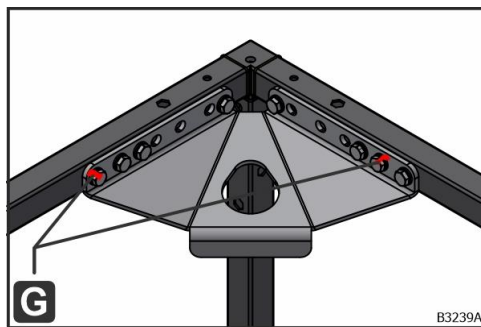

Fig. 77: G – screw locking lacquer

For rectification of faults see chapter "Fault", page 78.

- Visually inspect all parts for cracks, corrosion and/or deformation. If there are any abnormalities, the motor removal device must not be put into operation.
- Check the fastening of the corner nodes (A). Each corner node (A) must be secured with 8 screws. If incomplete, the motor removal device must not be put into operation.
- Carry out a visual inspection of the screw locking lacquer (G) on the corner nodes (A). If there is any damage, the motor removal device must not be put into operation.

The condition of the factory installed fasteners, the parts to be installed on site, the lever hoists (J) and the sling chains (K) must be checked:

- Visually inspect all parts for cracks, corrosion and/or deformation. If there are any abnormalities, the lift out device must not be put into operation.
- The centring pins (P) of the support struts (H) must be inserted into the grooves of the upper suspension brackets (F).

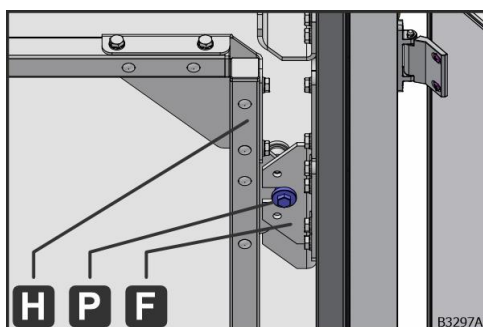

Fig. 78: centring pin (P) in upper suspension bracket (F)

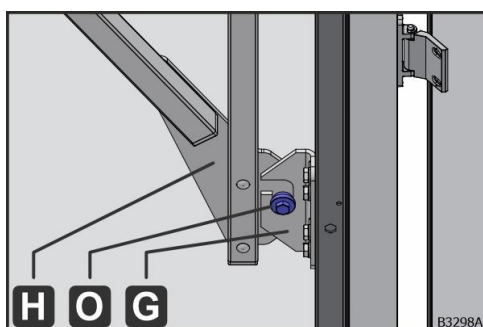

Fig. 79: centring pin (O) in lower suspension bracket (G)

- The centring pins (O) of the support struts (H) must be inserted into the grooves of the lower suspension brackets (G).

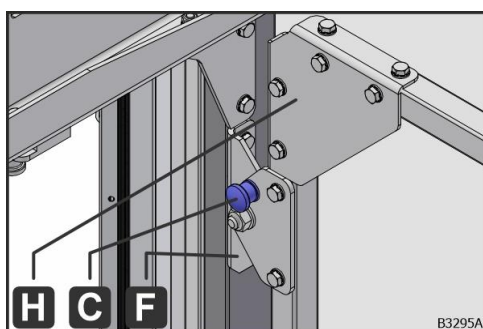

Fig. 80: C-M10 mini indexing plunger (C) in upper suspension bracket (F)

- The C-M10 mini indexing plungers (C) on the support struts (H) right and left must be engaged in the upper suspension bracket (F).

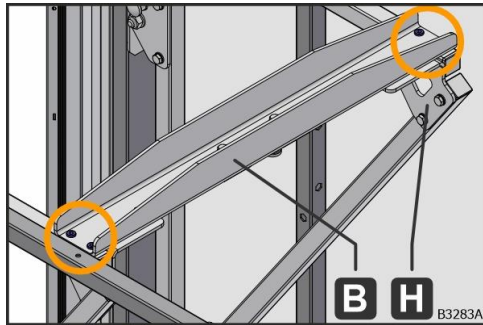

Fig. 81: cylinder head screws in centring boreholes

- The centring boreholes of the mounting section (B) must be engaged in the screw heads of the cylinder head screws of the support struts (H).

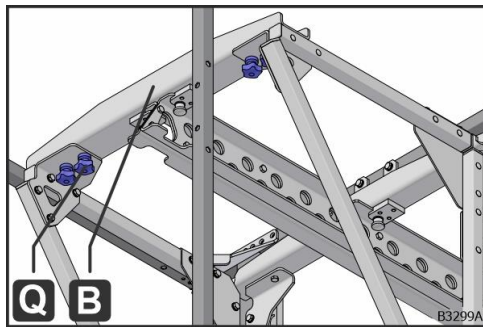

Fig. 82: M8 star grips in support struts

- the mounting section (B) must be screwed onto the support struts with 4 M8 star grips (Q). The 4 M8 star grips (Q) must be fastened hand-tight.

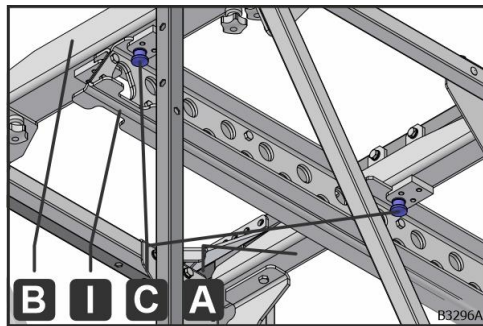

Fig. 83: mini indexing plungers (C) in guide plates

- The mini indexing plungers (C) in the guide plates front and back must be properly engaged.

For rectification of faults see chapter "Fault", page 78.

## Operation

### **Impeller suspension for AC motors**

For fans with AC motors, the impeller must be taken off before removing the motor see chapter "Impeller suspension for AC motors", page 70.

## Attaching the sling chains

### NOTICE



#### Material damage due to wrongly attached load

The anchorage eyelets of the load are not designed for oblique pull.

- Use the sling chain to attach the load.

The sling chains (B) are attached to the existing anchorage eyelets of the load (e.g. electric motor) with one or two hooks.

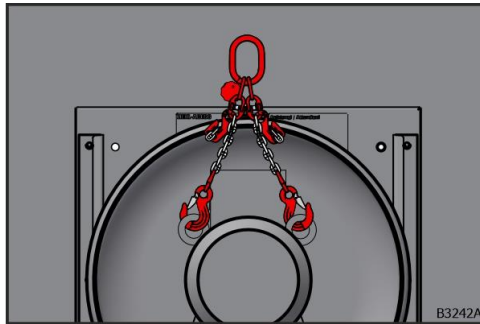

Fig. 84: attaching the sling chains to two anchorage eyelets

- Hook the sling chains into the existing anchorage eyelets of the load (e.g. electric motor).

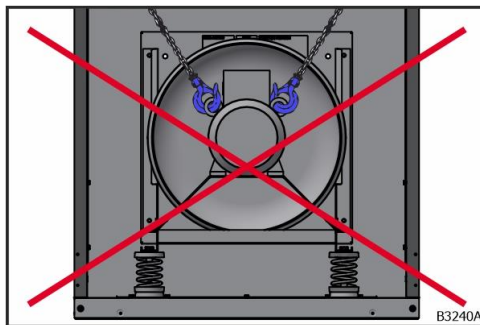

Fig. 85: Load attached wrongly

By using chain shortening hooks, the length of the sling chains (B) can be adjusted to the requirements of the specific situation.

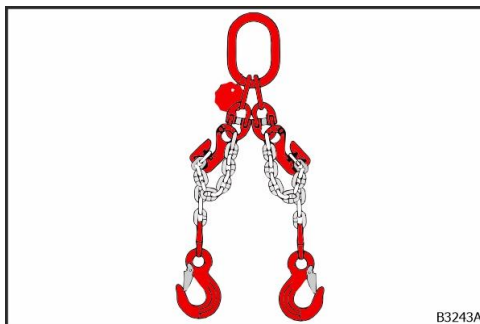

Fig. 86: using the chain shortening hooks

- The sling chains (B) can be shortened to a minimum using chain shortening hooks.



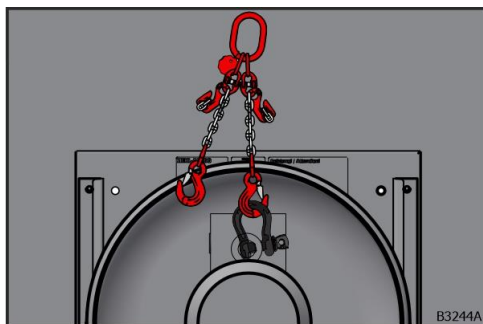

Fig. 87: attaching the sling chains to an anchorage eyelet

- With an anchorage eyelet, a shackle can be inserted into the centre of it.

### Determining the 3 corner nodes for attaching the lever chain hoists

The load is statically suspended from 3 lever chain hoists. As the lever chain hoists can only be loaded in tension due to the chains as the means of traction, the lever chain hoists must always be arranged in a star shape (when viewed from above). None of the chains may form an angle of more than  $180^\circ$  to the neighbouring chain.

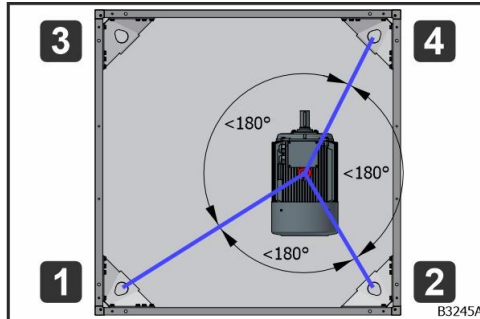

Fig. 88: correct use of corner nodes 1, 2 and 3

- Using corner nodes 1, 2 and 4: all angles are less than  $180^\circ$ .

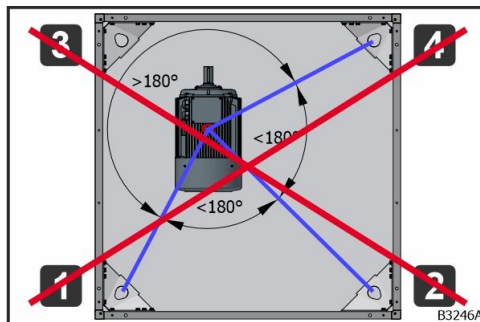

Fig. 89: wrong use of corner nodes 1, 2 and 3

- Using corner nodes 1, 2 and 4: one angle is greater than  $180^\circ$ . The load must not be lifted, as it may swing uncontrollably in the direction of corner node 2.
- Unhook lever chain hoist from corner node 2 and reattach at corner node 3.

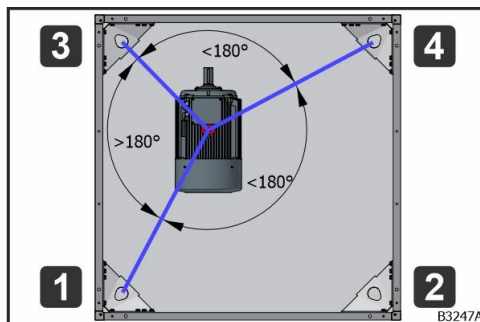

Fig. 90: correct use of corner nodes 1, 3 and 4

- Using corner nodes 1, 3 and 4: all angles are less than  $180^\circ$ .

## Adjusting the length of the lever chain hoists

### WARNING



#### Risk of injury from falling or swinging load

If the changeover lever of the lever chain hoist is set to the freewheel position "N" when the load is below the minimum load, the load may move in an uncontrolled manner. This may result in injury due to the load swinging or falling.

- No lifting and clamping operations when the changeover lever is in the freewheel position "N".
- Do not select freewheel position "N" when loaded.

The chain is set to the correct length with the freewheel of the lever chain hoist.

#### Requirement

- No load is attached to the lever chain hoist.
- The lever chain hoist is not under tension.

#### Work steps

1. Set the changeover lever (M) to freewheel position "N".
2. Turn the handwheel (L) anti-clockwise until it locks.
  - ➔ The brake is released.
3. Pull the chain into the required position.
  - ➔ The chain is set to the correct length.

## Tightening the lever chain hoists to lift the load

### TIP



#### Lever chain hoist braking mechanism

The braking mechanism is only activated in the "UP" position by applying the following minimum loads:

- DD-LB 075 35daN
- DD-LB 150 38daN
- DD-LB 300 50daN

#### Requirement

- Ensure that there are no persons or blocking parts in the immediate movement area of the load.

#### Work steps

1. Set the changeover lever (M) to the "UP" position.
2. Turn the handwheel (L) clockwise to tension the chain.
3. Turn the hand lever (N) clockwise to lift the load.
  - ➔ The load is lifted.

### **Releasing the lever chain hoists and lowering the load**

#### Requirement

- Ensure that there are no persons or blocking parts in the immediate movement area of the load.

#### Work steps

- Set the changeover lever (M) to the "DN" (down) position.
- Turn the hand lever (N) anti-clockwise to slowly lower the load.
- The load is lowered.

### Moving the load diagonally

The following steps are required to move the load from one corner to the diagonally opposite corner (e.g. from corner node 4 to corner node 2):

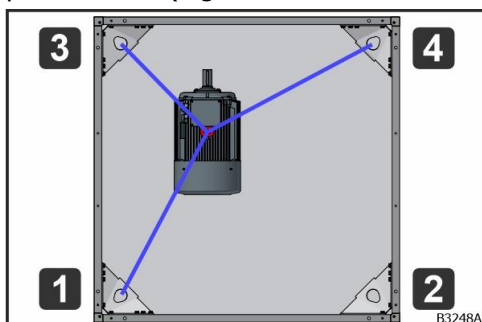

Fig. 91: load with corner node 4

1. Tighten all 3 lever chain hoists.
  2. Tighten lever chain hoists 1 and 4 further and loosen lever chain hoist 3.
- The load moves towards the casing centre.

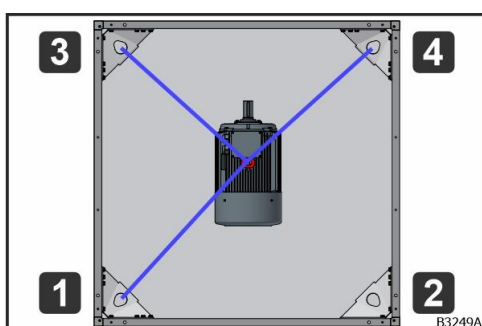

Fig. 92: load in centre of casing with lever chain hoist in corner node 4

Chains of lever chain hoist 1 and 4 are in line.

3. Release lever chain hoist 3.
4. Detach lever chain hoist from corner node 3.

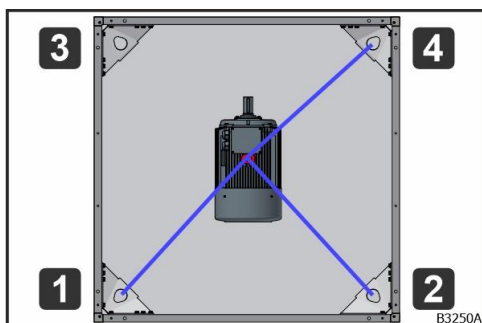

Fig. 93: load in centre of casing with lever chain hoist in corner node 2

Chains of lever chain hoist 1 and 4 are in line.

5. Attach lever chain hoist to corner node 2.

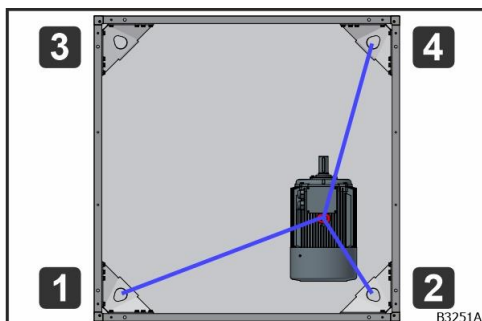

Fig. 94: load moves towards corner node 2

6. Release the chains of lever chain hoists 1 and 4 and tighten lever chain hoist 2.
- The load moves towards corner node 2.

## Impeller suspension for AC motors

For fans with AC motors, the impeller must be taken off before removing the motor.

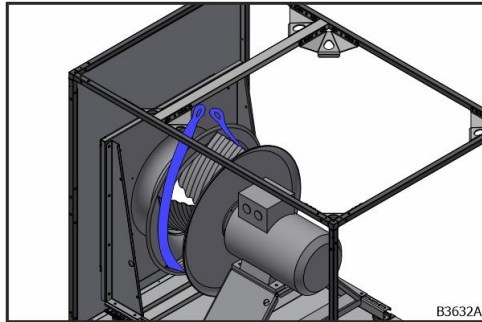

Fig. 95: Impeller with polyester sling

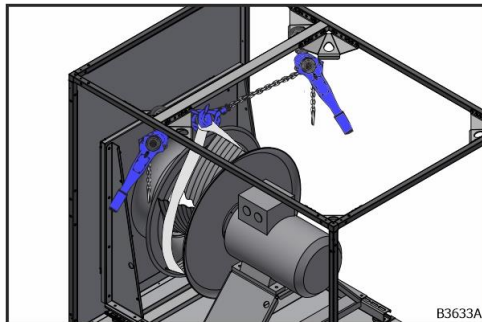

Fig. 96: Lever chain hoists in the corner brackets

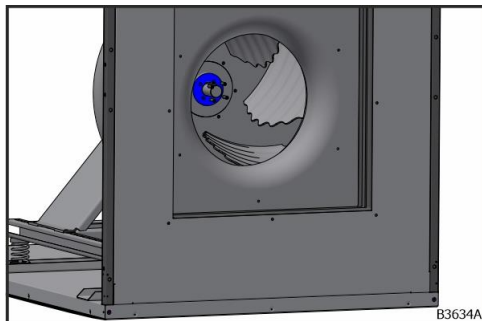

Fig. 97: Impeller bushing

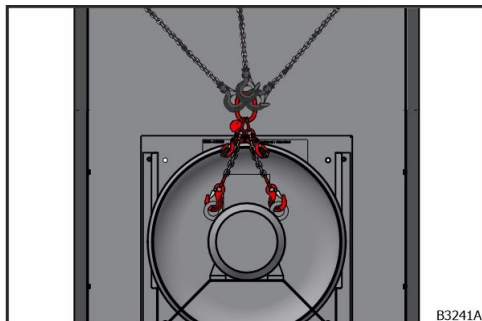

Fig. 98: Suspended motor

1. Lay the polyester sling round the impeller.
2. Attach the polyester sling to two corner brackets above the impeller using shackles in two lever chain hoists.
3. Pull the lever chain hoists until there is a slight tension see chapter "Adjusting the length of the lever chain hoists", page 67, see chapter "Tightening the lever chain hoists to lift the load", page 67 and see chapter "Releasing the lever chain hoists and lowering the load", page 68.
4. Detach the impeller bushing from the intake side.
5. Attach the sling chains to the existing anchorage eyelets of the AC motor see chapter "Attaching the sling chains", page 64.
6. Attach the load hook of the lever chain hoists to the lug of the sling chain see chapter "Determining the 3 corner nodes for attaching the lever chain hoists", page 66.

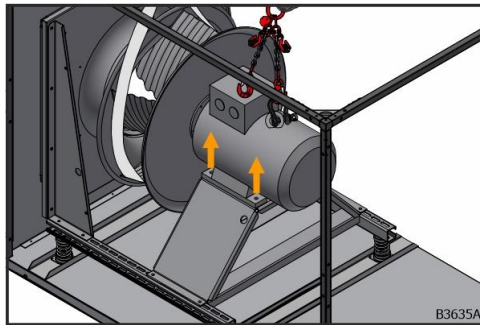

Fig. 99: Motor mount screws

7. Remove the screws attaching the motor to the motor mount.

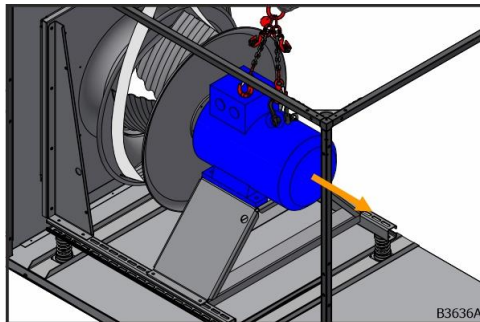

Fig. 100: Pulling out the motor

8. Pull the motor with drive shaft out of the impeller.  
→ The motor can now be removed see chapter "Moving the load diagonally", page 69.

## Work steps for removing a load

### WARNING



#### Danger to life caused by swinging loads

There is a danger to life from the attached load swinging.

- When lifting, the attached load must be vertically below the lifting point of the supporting arm (I).

#### Requirements

The factory installed fasteners must be mounted. The inspection door must be open or the panel removed at the corresponding opening.

Attaching the lever hoists (J) to the supporting arm (I)

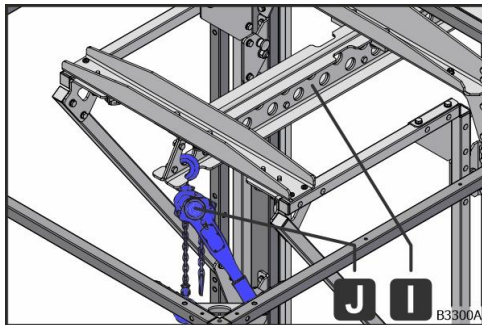

Fig. 101: inner lifting point

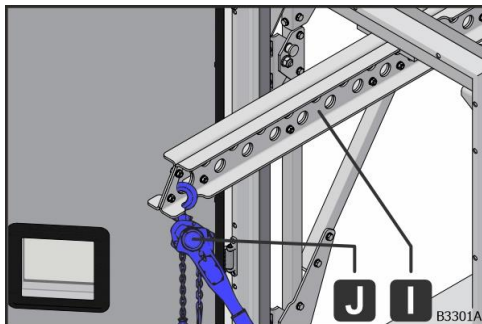

Fig. 102: external lifting point

1. Attach a lever hoist (J) to the inner lifting point of the supporting arm (I).

2. Attach the second lever hoist (I) to the external lifting point of the supporting arm (I).

Attaching the lever hoists (J) to the sling chain (K)

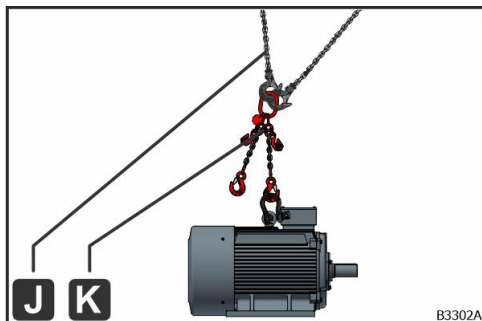

Fig. 103: load hook in sling chain (K)

1. Hook the load hooks of the lever hoists (J) into the eye of the sling chain (K).



## Lifting out the load

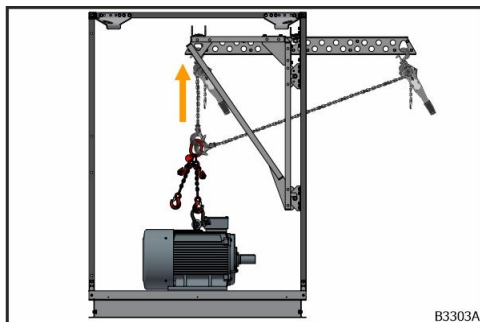

Fig. 104: load inside the casing

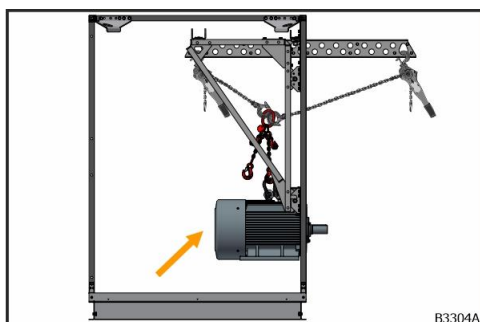

Fig. 105: load in intermediate position

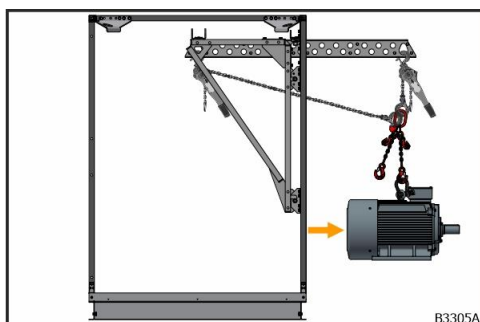

Fig. 106: load vertically below the outer lever hoist

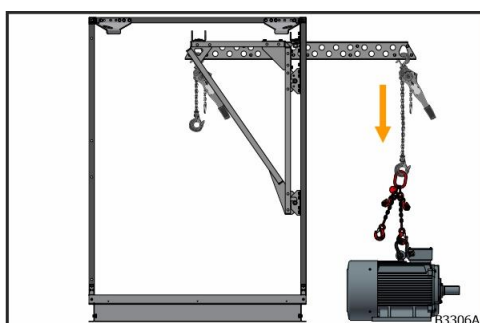
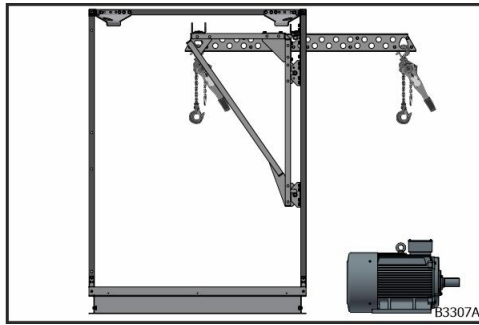

Fig. 107: load outside the casing

1. Tighten the inner lever hoist (J) to lift the load.
2. Tighten the outer lever hoist (J) to swivel the load towards the opening.
3. Loosen the inner lever hoist (J) to move the load more towards the opening. In the process, the load lowers.
4. Tighten the outer lever hoist (J) to counteract lowering and carry on moving the load towards the opening.
5. Repeat work steps 3 and 4 until the load is suspended vertically on the outer lever hoist (J).
6. Unhook the load hook of the inner lever hoist (J).
7. Release the outer lever hoist (J) to set down the load.



8. Unhook the load hook of the outer lever hoist (J).
- The load is lifted out.

Fig. 108: load set down

### **Lifting in the load**

Lifting in the load takes place in the reverse order of lifting out.

## Maintenance

### Maintenance interval

Every year.



Fig. 109: inspection sticker (lever chain hoist)

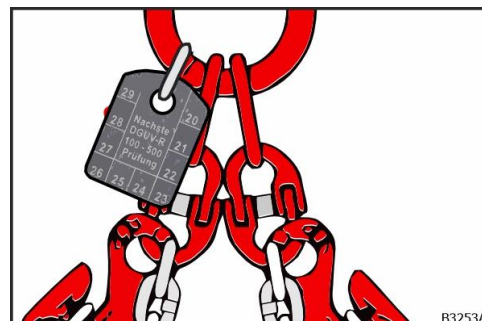

Fig. 110: inspection mark (sling chain)

The inspection sticker or inspection mark indicates the next required inspection.

### Inspection

The condition of the corner nodes (A), the lever hoists (B) and the sling chains (C) must be checked:

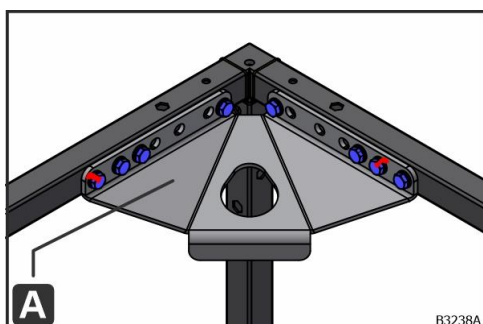

Fig. 111: Fastening the corner nodes

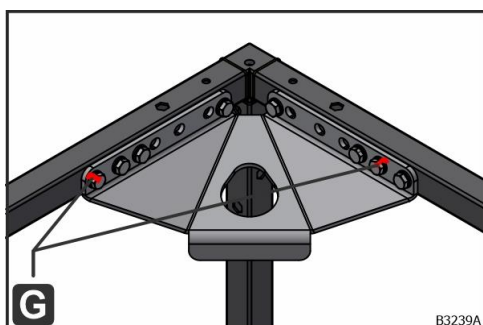

Fig. 112: G – screw locking lacquer

For rectification of faults see chapter "Fault", page 78.

- Visually inspect all parts for cracks, corrosion and/or deformation. If there are any abnormalities, the motor removal device must not be put into operation.
- Check the fastening of the corner nodes (A). Each corner node (A) must be secured with 8 screws. If incomplete, the motor removal device must not be put into operation.
- Carry out a visual inspection of the screw locking lacquer (G) on the corner nodes (A). If there is any damage, the motor removal device must not be put into operation.

The condition of the factory installed fasteners, the parts to be installed on site, the lever hoists (J) and the sling chains (K) must be checked:

- Visually inspect all parts for cracks, corrosion and/or deformation. If there are any abnormalities, the lift out device must not be put into operation.
- The centring pins (P) of the support struts (H) must be inserted into the grooves of the upper suspension brackets (F).

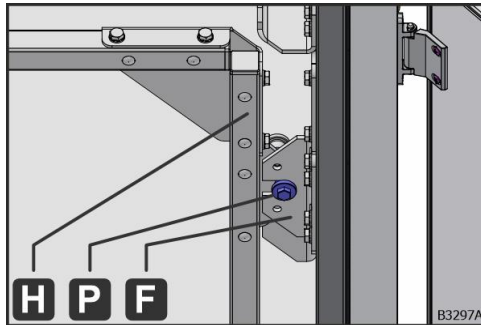

Fig. 113: centring pin (P) in upper suspension bracket (F)

- The centring pins (O) of the support struts (H) must be inserted into the grooves of the lower suspension brackets (G).

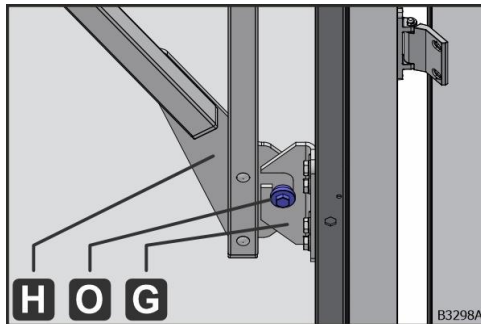

Fig. 114: centring pin (O) in lower suspension bracket (G)

- The C-M10 mini indexing plungers (C) on the support struts (H) right and left must be engaged in the upper suspension bracket (F).

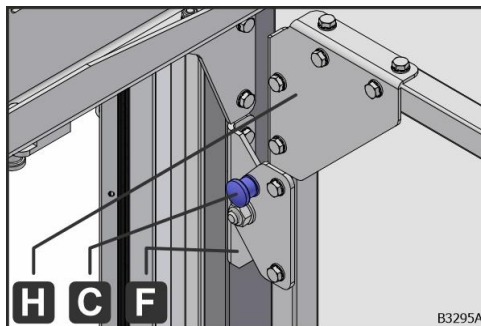

Fig. 115: C-M10 mini indexing plunger (C) in upper suspension bracket (F)

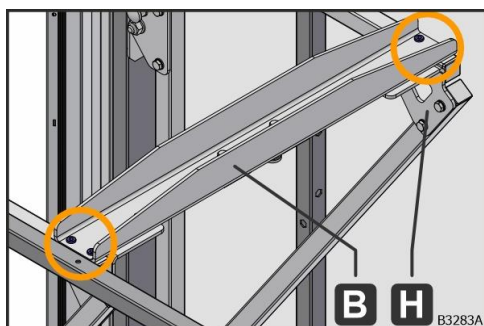

Fig. 116: cylinder head screws in centring boreholes

- The centring boreholes of the mounting section (B) must be engaged in the screw heads of the cylinder head screws of the support struts (H).

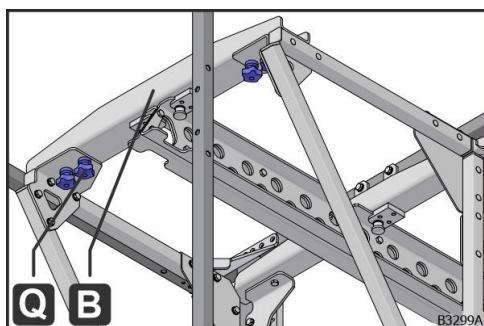

Fig. 117: M8 star grips in support struts

- the mounting section (B) must be screwed onto the support struts with 4 M8 star grips (Q). The 4 M8 star grips (Q) must be fastened hand-tight.

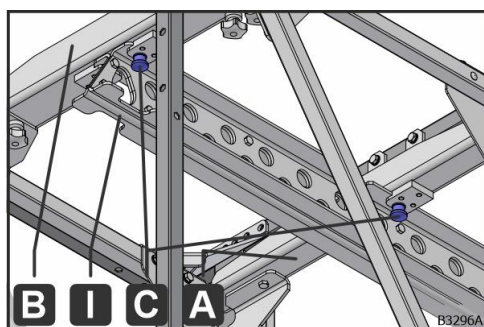

Fig. 118: mini indexing plungers (C) in guide plates

- The mini indexing plungers (C) in the guide plates front and back must be properly engaged.

For rectification of faults see chapter "Fault", page 78.

## **Fault**

### **Defective parts**

In the event of any faults or defective parts in the motor removal device, these must be rectified by appropriately trained personnel.

- Do not bend any bent parts back into shape. Replace bent parts with original spare parts.
- Do not weld cracked parts. Replace cracked parts with original spare parts.

The disassembly and assembly of the parts must be carried out professionally, taking into account and with an understanding of the function and load of the parts. The work carried out must also be checked and confirmed by qualified personnel.

### **Interrupted screw locking lacquer**

The screw locking lacquer must not be interrupted. Proceed as follows if the screw locking lacquer is interrupted:

1. Have the cause determined by appropriately trained personnel.
2. Tighten the screw with a torque of 20 Nm.
3. Apply screw locking lacquer.

The work carried out must be checked and confirmed by qualified personnel.

# Heat recovery systems (HRS)

## Plate heat exchanger

### Inspection

#### Maintenance interval

Every three months.

#### Work steps

- Check plate heat exchanger for hygienic condition, foreign matter, contamination, damage, and corrosion.
- Check pan drain and siphon for function; clean if necessary.
- Check siphon water filling and refill if necessary.
  - Perform an electrical safety check of the connection to the equipotential bonding conductor of the AHU see chapter "Electrical safety tests ", page 111.

### Repair

#### WARNING



#### **Risk of explosion due to the plate coil being installed with an inadequate connection to the equipotential bonding of the AHU**

If the plate coil is not adequately connected to the AHU floor, the plate coil may become statically charged. The discharge and the resulting sparks may cause an explosion.

- Lay the plate coil on a clean unit floor to establish equipotential bonding with the AHU.
- Eliminate foreign matter, contamination, damage and corrosion
  - Cleaning with compressed air or high pressure cleaner (only water without additives). To avoid damage during cleaning, direct the air or water jet only at a right angle to the inflow surface of the plate heat exchanger. Carefully remove wastewater.

# Heating and cooling coils

## WARNING



### **Risk of explosion due to leakages in coils**

Leakages in the area of the coil can result in a potentially explosive atmosphere reaching the hydraulic set via the pipework. In conjunction with a source of ignition, this may result in an explosion.

- Prevent frost damage by providing frost protection on site (e.g. sufficient antifreeze).
- Check the tightness of the coil, the pipework and the hydraulic set according to the instructions and the maintenance interval (see "Maintenance and cleaning" operating instructions, "Hydraulic set" section and "Heating and cooling coils" section).



## Heating coil

### NOTE



#### **Material damage due to inadequate venting**

If systems are not properly vented, air pockets will form which can lead to reduced performance or pump damage.

- Exhaust ventilate the system according to VDI 2035 during system filling at the highest point of the system.

Hydraulic sets have a variety of potential sources of ignition and may only be used in safe areas.

## Inspection

### **Maintenance interval**

Monthly.

### **Work steps**

- Check the coil, pipework and hydraulic set for damage, tightness and corrosion.

### **Maintenance interval**

Every three months.

### **Work steps**

- Check the coil for hygienic condition, contamination on the airside, damage, tightness, and corrosion.
- Exhaust ventilate the coil according to VDI 2035.
- Check the function of the supply and medium return lines.
- Check frost protection for function (medium by spinning out or temperature sensor using cold spray).
  - Perform an electrical safety check of the connection to the equipotential bonding conductor of the AHU see chapter "Electrical safety tests ", page 111.

## Repair

### WARNING



#### **Risk of explosion from electrostatic discharge**

Cleaning the AHU with a dry cloth may cause a static charge. The discharge and the resulting sparks may cause an explosion.

- Only wipe the AHU with a damp cloth.
- Follow the instructions in the operating instructions.

### WARNING



#### **Risk of explosion due to the coil being installed with an inadequate connection to the equipotential bonding of the AHU**

If the coil is not adequately connected to the AHU floor, the coil may become statically charged. The discharge and the resulting sparks may cause an explosion.

- Lay the coil on a clean unit floor to establish equipotential bonding with the AHU.

- Clean the coil on the airside, remove damage, leaks, and corrosion.
  - Clean the coil while installed or, if it is not accessible, remove it for cleaning. Removed dirt must not get into adjacent parts of the plant. Carefully remove dirt and wastewater.
  - Avoid bending the fins.
  - Blow out with compressed air against the air direction.
  - Do not use a high-pressure cleaner or high-pressure steam cleaner.
  - Clean with water and low pressure.

### **Removal/installation**

#### Requirements

- Disable the coil.
- Hydraulic set or pipework (medium supply and medium return) removed.

#### Work steps

1. Unscrew front panel with Torx (Tx25).
2. For the cooling coil, remove the condensate deflector plate from the casing frame.
3. Pull out the coil to the front.
4. Support the coil if necessary.
5. Check seals for damage and replace if necessary.
6. Insert the coil.
7. For the cooling coil, glue the condensate deflector plate with joint sealant.
8. Screw on front panel with Torx (Tx25).
9. Clean soiled surfaces (unit floor, drain pan and casing frame) with a damp cloth, as the position of the coils on the unit floor, the drain pan or the casing frame provides a conductive connection and ensures that the component is included in the equipotential bonding of the unit.
10. Check the connecting elements for corrosion.
11. Replace corroded connecting elements.
12. Slide in the coil.

13. Glue the condensate deflector plate on the cooling coil with joint sealant.
  14. Attach the front panel with Torx (Tx25).
- Perform an electrical safety check of the connection to the equipotential bonding conductor of the AHU see chapter "Electrical safety tests ", page 111.

### Making the flange connection

Requirements

Flange contact surfaces must be clean, flat and undamaged.

Work steps

#### NOTICE



#### Material damage due to incorrect tightening of the screws

Incorrect sequence when tightening the screws may cause material damage due to stresses.

- Tighten the screws crosswise.

Tighten the flange connections with the following tightening torque using a torque wrench, depending on the nominal diameter of the screw:

Nominal diameter of screw	Tightening torque [Nm]
M10	35
M12	55
M16	120
M20	240

Table 5: Torques for flange connections

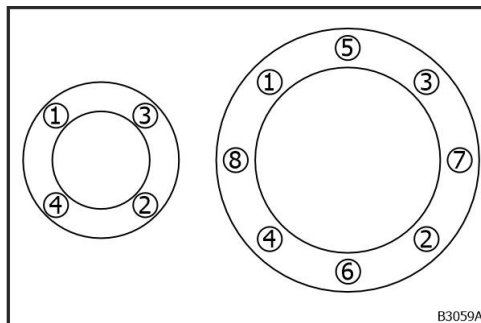

Fig. 119: tightening crosswise

The screws are tightened with a torque wrench in the sequence shown (= crosswise) in 3 passes:

1. Fix the screws crosswise with 30% of the tightening torque.
  2. Tighten the screws crosswise with 60% of the tightening torque.
  3. Tighten the screws crosswise with the tightening torque.
- The flange connection has been made correctly.
4. Check the tightening torque of all screws.

## Cooling coil

### NOTE



#### **Material damage due to inadequate venting**

If systems are not properly vented, air pockets will form which can lead to reduced performance or pump damage.

- Exhaust ventilate the system according to VDI 2035 during system filling at the highest point of the system.

Hydraulic sets have a variety of potential sources of ignition and may only be used in safe areas.

### Inspection

#### **Maintenance interval**

Monthly.

#### **Work steps**

- Check the coil, pipework and hydraulic set for damage, tightness and corrosion.

#### **Maintenance interval**

Every three months.

#### **Work steps**

- Check the coil for hygienic condition, contamination on the airside, damage, tightness, and corrosion.
- Exhaust ventilate the coil according to VDI 2035.
- Check the function of the supply and medium return lines.
- Check frost protection for function (medium by spinning out or temperature sensor using cold spray).
- Check condensate pan for contamination, clean if necessary.
- Check water drain and siphon for function; clean if necessary.
- Check water supply siphon and refill if necessary.
- Check direct expansion coil for ice formations.
- Check droplet eliminator for sanitary condition, contamination, incrustation, damage, droplet penetration, and corrosion.
  - Perform an electrical safety check of the connection to the equipotential bonding conductor of the AHU see chapter "Electrical safety tests ", page 111.

## Repair

### WARNING



#### **Risk of explosion from electrostatic discharge**

Cleaning the AHU with a dry cloth may cause a static charge. The discharge and the resulting sparks may cause an explosion.

- Only wipe the AHU with a damp cloth.
- Follow the instructions in the operating instructions.

### WARNING



#### **Risk of explosion due to the coil being installed with an inadequate connection to the equipotential bonding of the AHU**

If the coil is not adequately connected to the AHU floor, the coil may become statically charged. The discharge and the resulting sparks may cause an explosion.

- Lay the coil on a clean unit floor to establish equipotential bonding with the AHU.

- Clean the coil on the airside, remove damage, leaks, and corrosion.
  - Clean the coil while installed or, if it is not accessible, remove it for cleaning. Removed dirt must not get into adjacent parts of the plant. Carefully remove dirt and wastewater.
  - Avoid bending the fins.
  - Blow out with compressed air against the air direction.
  - Do not use a high-pressure cleaner or high-pressure steam cleaner.
  - Clean with water and low pressure.
- Clean and repair the droplet eliminator: Pull out cassette, disassemble and clean profiles individually; remove damage and corrosion.

### **Removal/installation**

#### Requirements

- Disable the coil.
- Hydraulic set or pipework (medium supply and medium return) removed.

#### Work steps

1. Unscrew front panel with Torx (Tx25).
2. For the cooling coil, remove the condensate deflector plate from the casing frame.
3. Pull out the coil to the front.
4. Support the coil if necessary.
5. Check seals for damage and replace if necessary.
6. Insert the coil.
7. For the cooling coil, glue the condensate deflector plate with joint sealant.
8. Screw on front panel with Torx (Tx25).
9. Clean soiled surfaces (unit floor, drain pan and casing frame) with a damp cloth, as the position of the coils on the unit floor, the drain pan or the casing frame provides a conductive connection and ensures that the component is included in the equipotential bonding of the unit.
10. Check the connecting elements for corrosion.

11. Replace corroded connecting elements.
  12. Slide in the coil.
  13. Glue the condensate deflector plate on the cooling coil with joint sealant.
  14. Attach the front panel with Torx (Tx25).
- Perform an electrical safety check of the connection to the equipotential bonding conductor of the AHU see chapter "Electrical safety tests ", page 111.

### Making the flange connection

Requirements

Flange contact surfaces must be clean, flat and undamaged.

Work steps

#### NOTICE



#### Material damage due to incorrect tightening of the screws

Incorrect sequence when tightening the screws may cause material damage due to stresses.

- Tighten the screws crosswise.

Tighten the flange connections with the following tightening torque using a torque wrench, depending on the nominal diameter of the screw:

Nominal diameter of screw	Tightening torque [Nm]
M10	35
M12	55
M16	120
M20	240

Table 6: Torques for flange connections

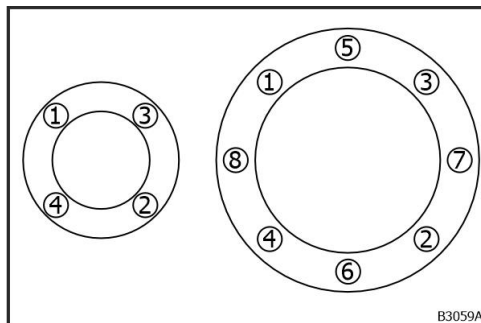

Fig. 120: tightening crosswise

The screws are tightened with a torque wrench in the sequence shown (= crosswise) in 3 passes:

1. Fix the screws crosswise with 30% of the tightening torque.
  2. Tighten the screws crosswise with 60% of the tightening torque.
  3. Tighten the screws crosswise with the tightening torque.
- The flange connection has been made correctly.
4. Check the tightening torque of all screws.



# Dampers

## Damper

### WARNING



#### **Risk of explosion from lack of equipotential bonding**

Non-existent or incorrectly connected equipotential bonding may cause components to become statically charged. The discharge may cause an explosion.



- Connect all factory installed equipotential bonding conductors and secure them to prevent them from loosening.
- Observe the work steps set out in the operating instructions.

### WARNING



#### **Risk of death due to moving parts**

Risk of death when closing fins, moving coupling bars or gears due to crushing between two moving parts.

- Attach separating protective devices (e.g., downstream grid, duct) to the damper.
- Before opening the door, switch off the AHU and secure it against restarting.
- Do not reach between the fins.

### NOTE



#### **Material damage due to improper commissioning**

Switching on the fan with the dampers closed may cause damage to the AHU.

- Do not switch on the fan before checking that the relevant dampers are open or before a limit switch indicates they are open.
- Make sure that the fans are switched off immediately when the shut-off dampers are closed.

## Inspection

### **Maintenance interval**

Every three months.

### **Work steps**

#### **Dampers**

- Check dampers for function, contamination, damage, and corrosion.
- Check the protective device for effectiveness.

#### **Dampers with rod drive**

- Check rods for tight fit and unobstructed movement.
- Check the setting.

Equipotential bonding:

- Perform an electrical safety check of the connection to the equipotential bonding conductor of the AHU see chapter "Electrical safety tests ", page 111.

## Repair

### WARNING



#### Risk of explosion due to the use of dampers with inadequate ignition protection

Using dampers without adequate ignition protection may cause static charging of the AHU. The discharge and the resulting sparks may cause an explosion.

- Use dampers that are at least compliant with the ATEX requirements of the AHU.

### Dampers

- Clean dampers; remove damage and corrosion.

#### Dampers with rod drive

- Lubricate brass bearings (plastic bearings do not require lubrication).
- Lubricate rods.

Equipotential bonding:

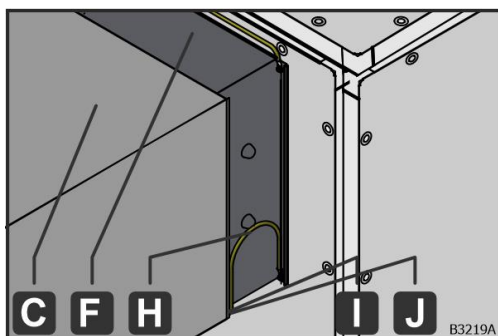

Fig. 121: damper with equipotential bonding conductor

1. Route the pre-assembled equipotential bonding conductor (H) of the damper (F) to the on-site duct (C).
  2. Secure the equipotential bonding conductor (H) with a toothed lock washer (J) to prevent loosening.
  3. Tighten the screw (I).
- The damper (F) is connected to the AHU and to the on-site duct (C) via the equipotential bonding conductor (H).

4. Check the connecting elements for corrosion.
  5. Replace corroded connecting elements.
- Perform an electrical safety check of the connection to the equipotential bonding conductor of the AHU see chapter "Electrical safety tests ", page 111.

# Hydraulic set

## WARNING



### **Risk of explosion due to leakages in coils**

Leakages in the area of the coil can result in a potentially explosive atmosphere reaching the hydraulic set via the pipework. In conjunction with a source of ignition, this may result in an explosion.

- Prevent frost damage by providing frost protection on site (e.g. sufficient antifreeze).
- Check the tightness of the coil, the pipework and the hydraulic set according to the instructions and the maintenance interval (see "Maintenance and cleaning" operating instructions, "Hydraulic set" section and "Heating and cooling coils" section).

Hydraulic sets have a variety of potential sources of ignition and may only be used in safe areas.

## Exhaust ventilating

## NOTE



### **Material damage due to inadequate venting**

If systems are not properly vented, air pockets will form which can lead to reduced performance or pump damage.

- Exhaust ventilate the system according to VDI 2035 during system filling at the highest point of the system.

Pumps with a venting device (e.g., high-pressure centrifugal pumps in heavy duty run around coils) must be exhaust ventilated again approx. 2 weeks after commissioning as part of scheduled maintenance. Observe manufacturer's information.

Pump bearings and mechanical seals may otherwise be damaged.

## Inspection

### Maintenance interval

Every three months.

### Work steps

- Check hydraulic set for contamination, damage, corrosion, and tightness.
- Exhaust ventilate the hydraulic set and, if necessary, the pump according to VDI 2035.
- Check filters; clean if necessary.
- Check all valves, slides and flaps for free movement; if necessary, lubricate spindle according to manufacturer's information.
- Check overpressure devices for activation pressure.
- Maintain pumps, control valves, and actuators according to manufacturer's information.

## Repair

- Clean hydraulic set, eliminate damage, leakage, and corrosion.
- Retighten screw connections and stuffing boxes.

### Removal/installation of coils

To replace coils see chapter "Removal/installation ", page 82.

# Control system

## WARNING



### **Risk of explosion due to the use of components with inadequate ignition protection**

Using parts without adequate ignition protection may cause static charging of the AHU, for example. The discharge and the resulting sparks may cause an explosion.

- Use parts in the AHU that are at least compliant with the ATEX requirements for the inside of the AHU.
- Use parts on the outside of the AHU or next to the AHU that at least fulfil the ATEX requirements next to the AHU.
- When assembling parts, only use cable glands, reducers and dummy plugs with the appropriate ATEX approval.

## Maintenance interval

Every year.

## Inspection

### **Sensors, control and safety devices**

- Check for correct and functional installation and ambient conditions.
- Check for dirt, corrosion, function and damage.
- Check connections for electrical/mechanical function, especially equipotential bonding.
- Measure and record physical parameters at the measuring point.
- Check electrical, electronic and pneumatic measuring signals.
- Check the indicators.

Further information on the maintenance of analogue differential pressure indicators see chapter "Dial gauge", page 97.

For further information on the maintenance of refrigerant sensors, see the appendix "Gas detectors with relay equalisation of the GS series", "Functional tests" section.

For further information on maintaining the duct smoke detector, see the "Duct smoke detector data sheet" annex in the "Scheduled maintenance and repair" section.

**Actuators**

- Check for professional and functional installation and environmental conditions.
- Check for contamination, corrosion, and damage.
- Check for external tightness (e.g., valve stuffing boxes).
- Check the electrical/mechanical function of the connections, especially equipotential bonding.
- Check electrical, electronic, and pneumatic input signals and working adjustment range.
- Check position sensor, limit sensor, and end position switch for function.
- Readjust.

## Repair

### Sensors, control and safety devices

- Function-preserving cleaning.
- Readjust, regenerate, replace if necessary.

Further information on the maintenance of analogue differential pressure indicators see chapter "Dial gauge", page 97.

For further information on maintaining the duct smoke detector, see the "Duct smoke detector data sheet" annex in the "Scheduled maintenance and repair" section.

### Actuators

- Lubricate (e.g., valve spindle).
- Function-preserving cleaning.



# Pressure measuring devices

## Analog differential pressure indicators

### Dial gauge

#### Inspection

- Check the assembly.
- Check for soiling and damage.
- Check connections of pressure measuring hoses.
- Check display.

#### Repair

- Perform zero adjustment (see chapter "Zero-point correction for dial gauges", page 98).
- Replace the dial gauge (see chapter "Exchanging dial gauge, in-wall mounting ", page 100).

## Zero-point correction for dial gauges

Structure of a dial gauge:

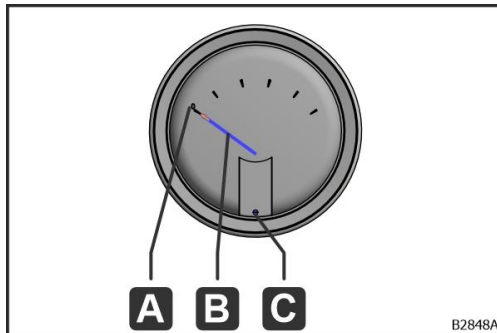

- A - "0": Zero point on the scale
- B - pointer
- C - Screw for zero point correction

Fig. 122: Structure of a dial gauge

Tool:

- flat-bladed screwdriver

Requirements:

- The fan is not operating.

Possible deviations:

- The pointer (B) is below "0" (A) see chapter "The pointer (B) is below "0" (A)", page 98.
- The pointer (B) is above "0" (A) see chapter "The pointer (B) is above "0" (A)", page 99.

Work steps: **The pointer (B) is below "0" (A)**

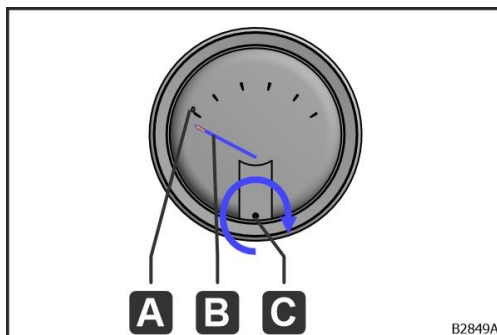

1. Turn the screw for zero adjustment (C) clockwise until the pointer (B) is at "0" (A).

Fig. 123: pointer (B) below

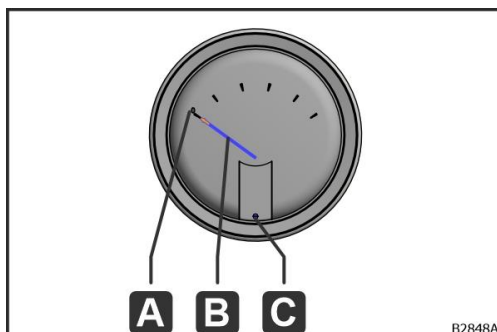

- Pointer (B) is on "0" (A).

Fig. 124: pointer (B) set correctly

Work steps: **The pointer (B) is above "0" (A)**

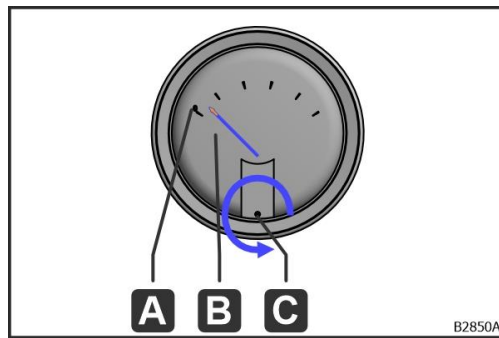

1. Turn the screw for zero adjustment (C) anti-clockwise until the pointer (B) is on "0" (A).

Fig. 125: pointer (B) above

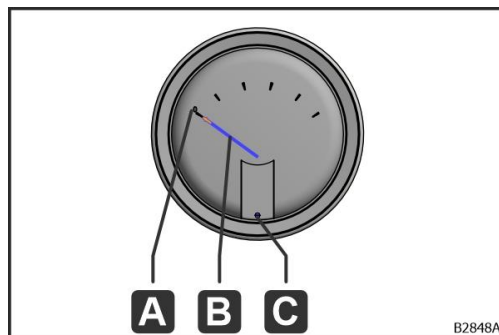

→ Pointer (B) is on "0" (A).

Fig. 126: pointer (B) set correctly

### Exchanging dial gauge, in-wall mounting

Tool: Removing dial gauge, in-wall mounting

- Cross-head screwdriver
- Pen for marking pressure measuring hoses

Work steps: removal of dial gauge, in-wall mounting

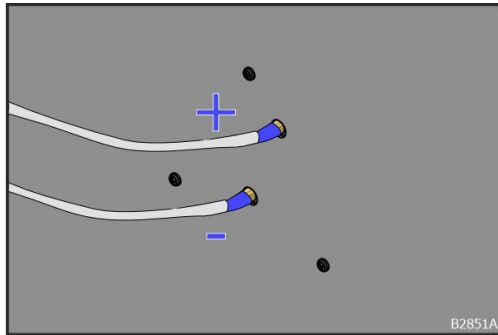

Fig. 127: marking with "+" and "-"

1. Mark the pressure measuring hoses.
  - Mark the upper pressure measuring hose with "+".
  - Mark the lower pressure measuring hose with "-".

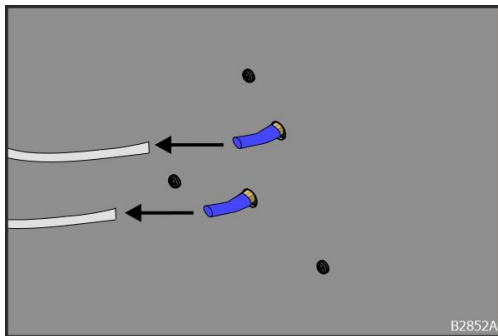

Fig. 128: removing the pressure measuring hoses

2. Remove the pressure measuring hoses.

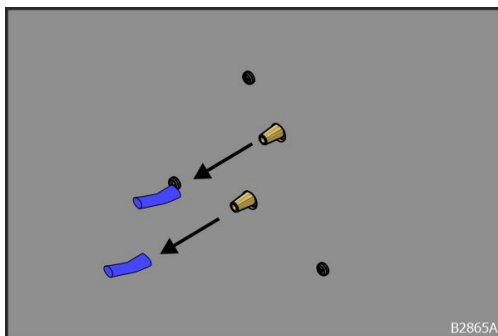

Fig. 129: removing the cuttings

3. Remove the plastic tube cutting.

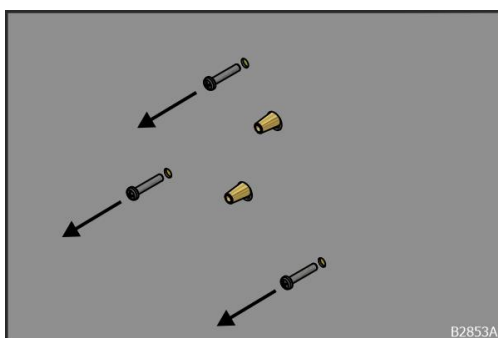
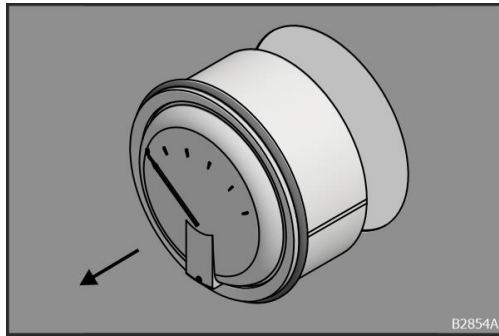

Fig. 130: removing the screws

4. Remove the crosshead screws with a crosshead screwdriver.



5. Remove the dial gauge from the panel.

Fig. 131: removing the dial gauge

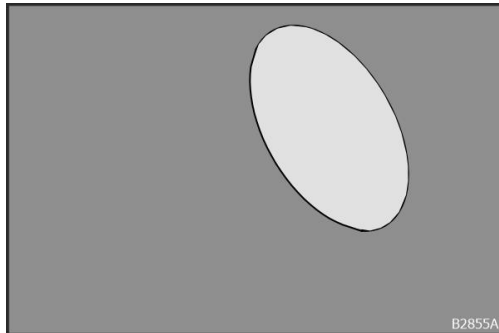

- The dial gauge is removed.

Fig. 132: dial gauge removed

Tool: Installing dial gauge, in-wall mounting

- Cross-head screwdriver
- Hexagon socket 3/18"
- Combination wrench 7/16"

Install material: Installing dial gauge, in-wall mounting

- Mounting kit for the integrated Magnehelic differential pressure gauge
  - 1x O-ring 107.32 mm
  - 2x O-ring 6.3 mm
  - 3x 5/8 Philips head screws
- Dial gauge with mounting kit
  - 1x dial gauge for in-wall mounting
  - 2x grub screws
  - 2x brass tube connectors
- 2x plastic hose cutting temp. 60° d=3.9, D=6.1, blue

Workflow: Installing dial gauge, in-wall mounting

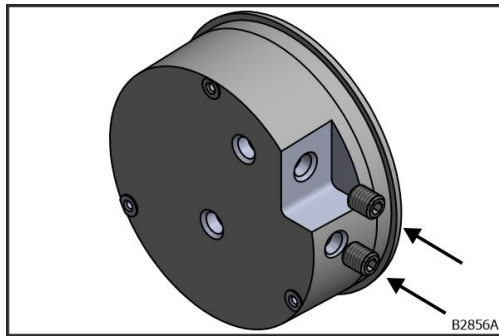

1. Close side pressure connections with grub screws using 3/18" hexagon socket.

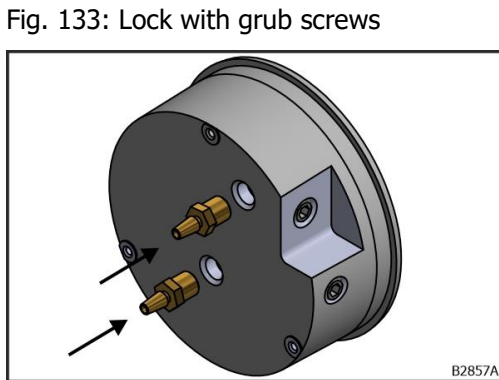

Fig. 133: Lock with grub screws

2. Screw brass hose nozzles into the pressure ports on the back with 7/16" ring and socket wrench.

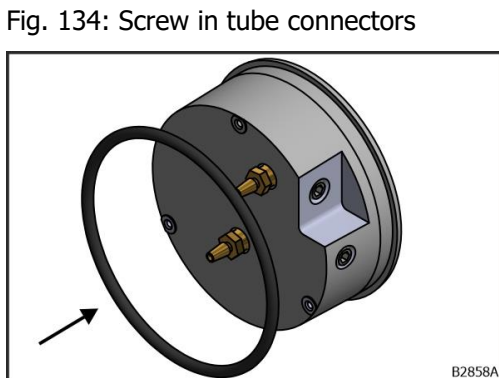

Fig. 134: Screw in tube connectors

3. Pull the 107.32 mm O-ring onto the casing.

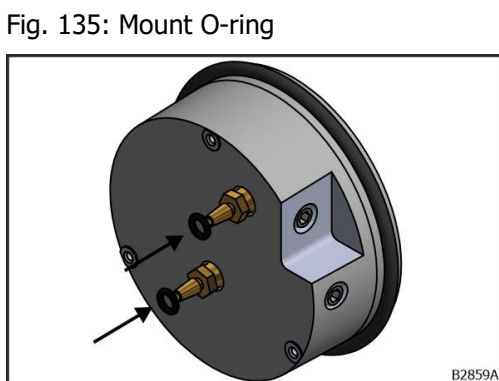

Fig. 135: Mount O-ring

4. Pull the 6.3 mm O-rings onto the brass hose nozzles.

Fig. 136: Tighten O-rings

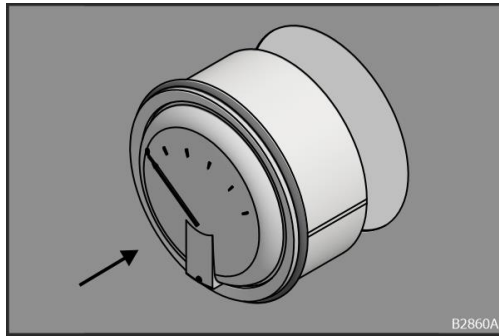

Fig. 137: Inserting dial gauge

5. Insert the dial gauge into the panel to match the hole pattern.

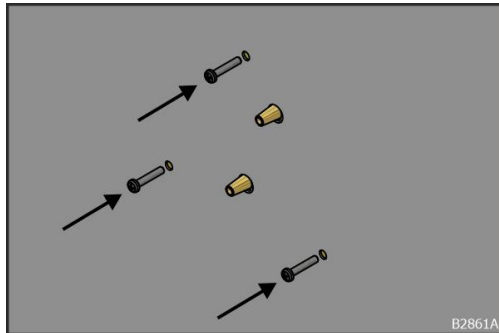

Fig. 138: Fasten with screws

6. Fasten the dial gauge with the 5/8 Phillips screws using a Phillips screwdriver.

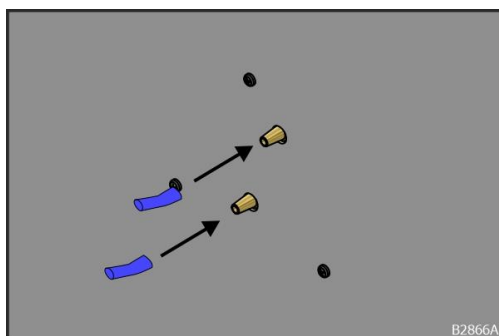

Fig. 139: Mounting cuttings

7. Fit plastic hose cutting.

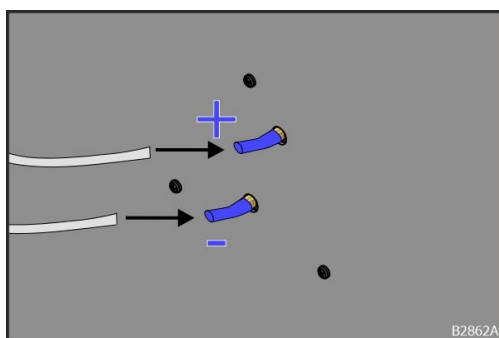
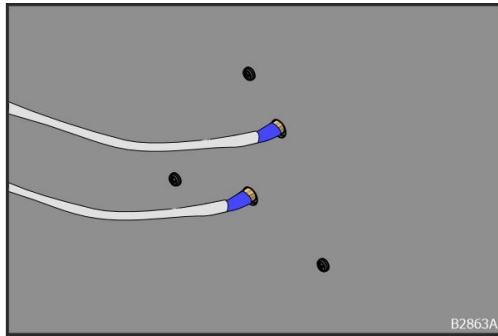

Fig. 140: Mounting pressure measuring hoses

8. Attach the pressure measuring hoses marked during removal to the brass hose nozzles.
  - Plug the pressure measuring hose with "+" onto the upper tube connector.
  - Plug the pressure measuring hose with "-" onto the lower tube connector.



→ The dial gauge has been correctly installed and connected.

Fig. 141: Dial gauge connected

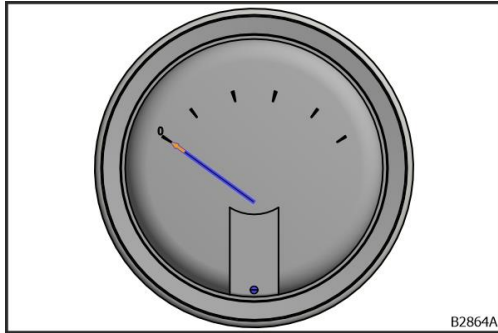

9. Perform zero-point correction (see chapter "Zero-point correction for dial gauges", page 98).

Fig. 142: Zero-point correction



## Removing dial gauge, wall mounting

Tool: Removing dial gauge, wall mounting

- Cross-head screwdriver
- Pen for marking pressure measuring hoses

Work steps: removal of dial gauges, wall mounting

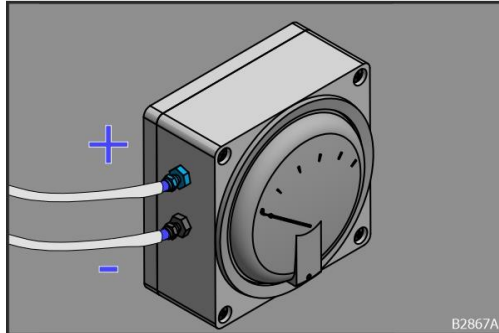

Fig. 143: marking with "+" and "-"

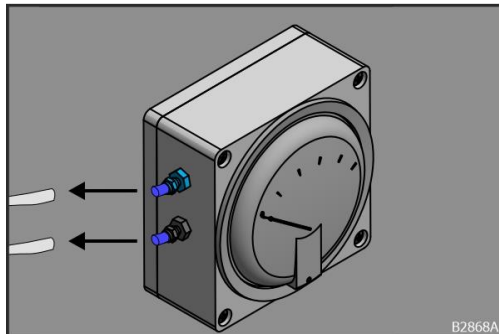

Fig. 144: removing the pressure measuring hoses

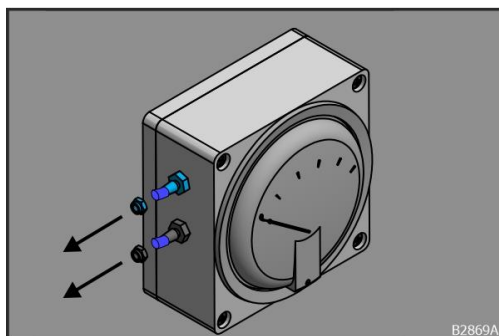

Fig. 145: removing the nuts

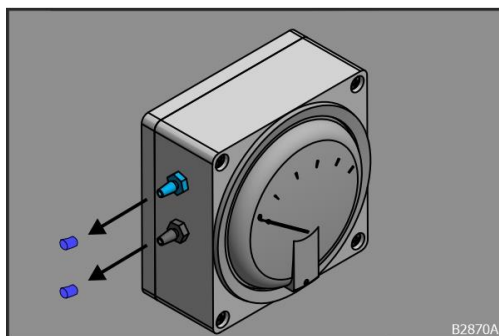
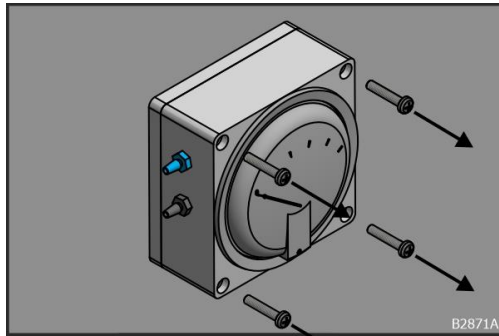

Fig. 146: removing the cuttings

1. Mark the pressure measuring hoses.
  - Mark the upper pressure measuring hose with "+".
  - Mark the lower pressure measuring hose with "-".
2. Remove the pressure measuring hoses.
3. Remove the nuts from the hose nozzles.
4. Remove the plastic tube cutting.



5. Remove the crosshead screws from the casing with a crosshead screwdriver.

Fig. 147: removing the screws

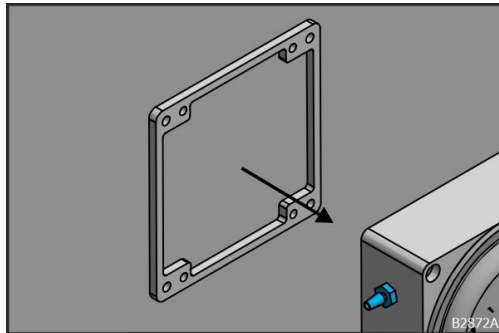

6. Remove the upper part of the casing.

Fig. 148: removing the casing

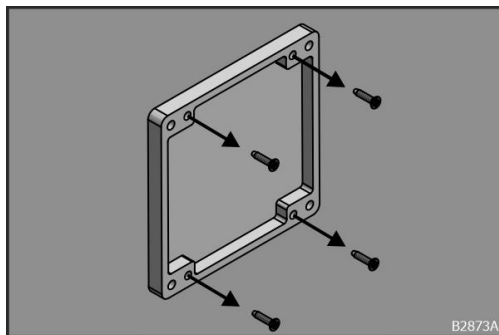

7. Remove the Phillips screws from the lower part of the casing.

Fig. 149: removing the screws

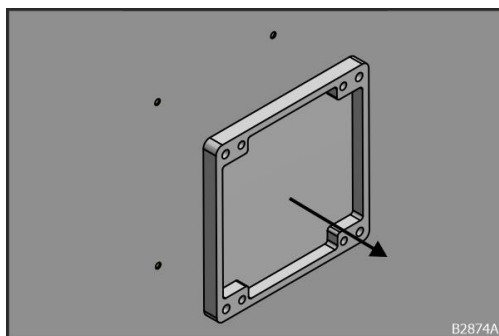

8. Remove the lower part of the casing from the panel.

Fig. 150: removing the casing

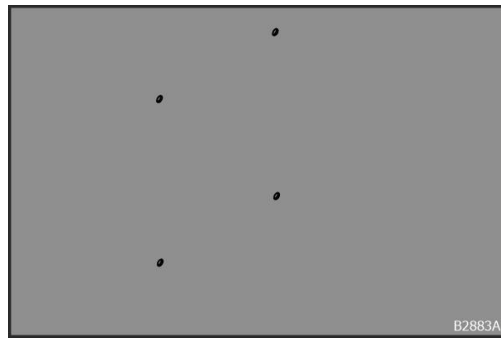

→ The dial gauge is removed.

Fig. 151: dial gauge removed

Tool: Installing dial gauge, wall mounting

- Cross-head screwdriver

Install material: Installing dial gauge, wall mounting

- 1x dial gauge for wall mounting
- 4x window screw JD-22 3.9x16 mm, galvanized
- 2x plastic hose cutting temp. 60° d=3.9, D=6.1, blue

Work steps: installation of dial gauge, wall mounting

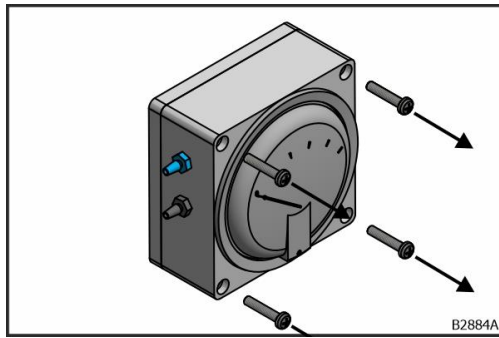

1. Open the casing of the dial gauge with a crosshead screwdriver.

Fig. 152: removing the screws

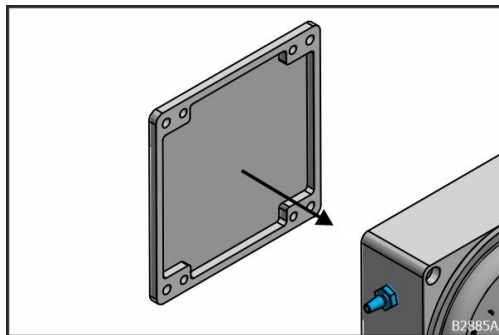

2. Open the casing.

Fig. 153: opening the casing

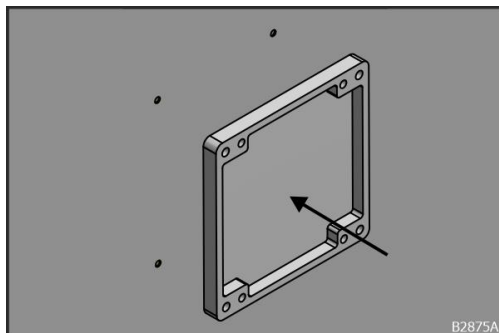

3. Place the lower part on the panel.

Fig. 154: positioning the casing

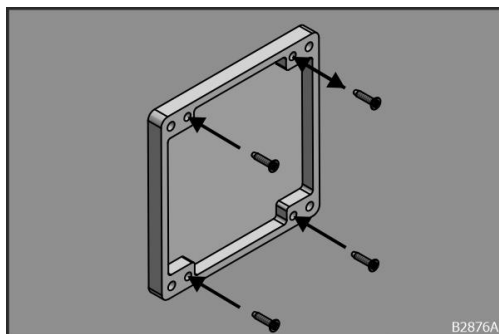

4. Fasten the lower part of the casing with JD-22 3.9 x 16 mm galvanised window screws in the existing holes in the panel using a crosshead screwdriver.

Fig. 155: fastening the casing

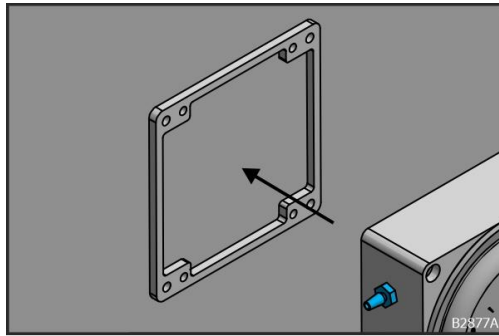

Fig. 156: positioning the casing

5. Position the upper part of the casing.

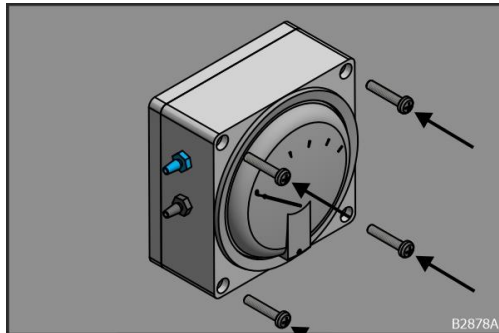

Fig. 157: positioning the casing

5. Mount the upper part of the casing with crosshead screws using a crosshead screwdriver.

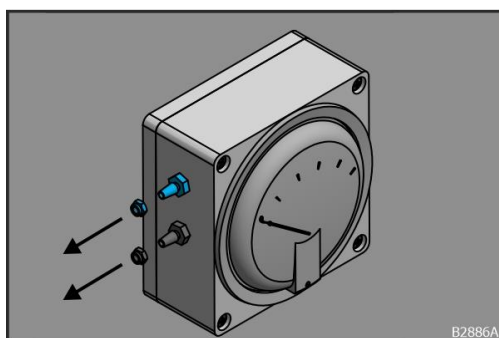

Fig. 158: removing the nuts

6. Remove the nuts from the hose nozzles.

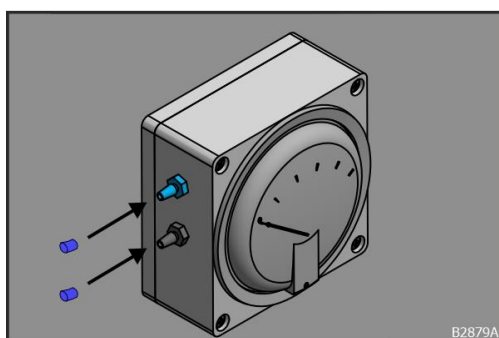

Fig. 159: pushing on the cuttings

7. Push the blue plastic tube cuttings (temp. 60° ID = 3.9, OD=6.1) onto the hose nozzles.

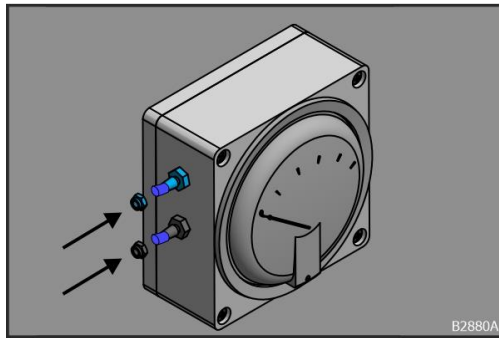

Fig. 160: screwing on the nuts

8. Screw the nuts onto the hose nozzles with plastic tube.

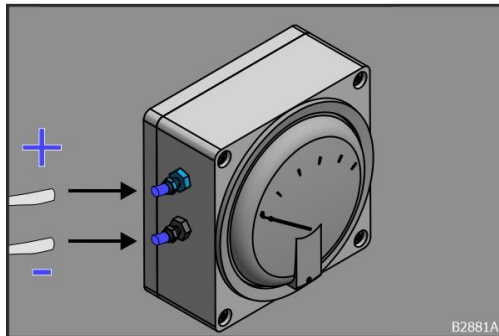

Fig. 161: pushing on the pressure measuring hoses

9. Attach the pressure measuring hoses marked during removal to the brass hose nozzles with plastic tube.
- Attach the pressure measuring hose with "+" to the upper hose nozzle.
  - Attach the pressure measuring hose with "-" to the lower hose nozzle.

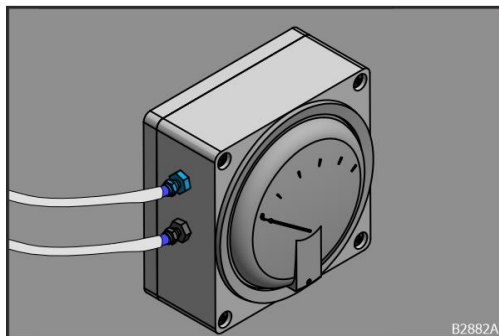

Fig. 162: dial gauge connected

→ The dial gauge has been properly installed and connected.

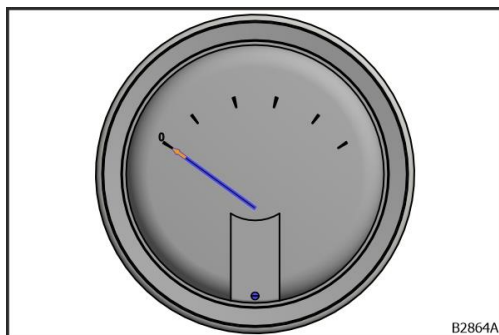

Fig. 163: Zero adjustment

10. Perform zero adjustment (see chapter "Zero-point correction for dial gauges", page 98).

# Electrical safety tests

## Personnel qualification

- Qualified electrician in explosion protection
- Qualified person in explosion protection

## Maintenance interval

Every three months.

## Work steps

Perform electrical safety tests in accordance with DIN EN 60204-1 (VDE 0113-1), observing the necessary safety precautions. The on-site mains connections must also meet the requirements of DIN EN 60204-1, Table 10.

In addition, the following tests must be carried out for ATEX units:

sufficient connection to the equipotential bonding of the AHU (base frame) must be checked for all metallic and coated parts. For example, these test parts include:

- Panels (external and internal sheets)
- Inspection doors (external and internal sheets)
- Unit floor (external and internal sheets)
- Drain pan (insulating sheet and pan sheet)
- Parts of mounting sets (e.g. tube and plates)
- Components (e.g. filters, silencers, fans, coils)
- Mounting parts (e.g. damper, sound-insulated connection)

Apply the test methods for uncoated, metallic parts in accordance with DIN EN 60079-32-2:

1. A screw or crocodile clip can be used at the earthing point of the AHU (borehole in the base frame labelled with a PE sticker).
2. Use a standard measuring electrode (test probe) on the test part.
3. Apply a test voltage of 100 V (15±5 s) between the earthing point of the AHU and the test part.
4. Read off the bleeder resistance.
5. A bleeder resistance of  $>10 \Omega$  is measured (in accordance with IEC 60079-32-1):
  - Check the equipotential bonding conductor and mounting set.
  - If necessary, clean the component support points.
  - If necessary, replace the equipotential bonding conductor.
  - Repeat the test.

A bleeder resistance of  $\leq 10 \Omega$  is measured (in accordance with IEC 60079-32-1):

- The correct function of all earthing measures is ensured.
- The build-up of a static potential difference, which could result in a static discharge posing the risk of an ignition source, is excluded.

Apply the test methods for coated, metallic parts in accordance with DIN EN 60079-32-2:

1. A screw or crocodile clip can be used at the earthing point of the AHU (borehole in the base frame labelled with a PE sticker).
  2. Use a standard measuring electrode (metal plate with circular area = 20 cm<sup>2</sup>) on the test piece.
  3. Apply a test voltage of 100 V (15±5 s) between the earthing point of the AHU and the test part.
  4. Read off the bleeder resistance.
  5. A bleeder resistance of >1 M Ω is measured (in accordance with IEC 60079-32-1):
    - Repeat the measurement with a test voltage of 500 V (65±5 s).  
A bleeder resistance ≤1 M Ω is measured (in accordance with IEC 60079-32-1):
      - The correct function of all earthing measures is ensured.
      - The build-up of a static potential difference, which could result in a static discharge posing the risk of an ignition source, is excluded.
    - A bleeder resistance of >1 M Ω is measured (in accordance with IEC 60079-32-1):
      - Check the equipotential bonding conductor and mounting set.
      - If necessary, clean the component support points.
      - If necessary, replace the equipotential bonding conductor.
      - Repeat the test.
- A bleeder resistance ≤1 M Ω is measured (in accordance with IEC 60079-32-1):
- The correct function of all earthing measures is ensured.
  - The build-up of a static potential difference, which could result in a static discharge posing the risk of an ignition source, is excluded.

The operator is obliged to repeat these checks regularly in accordance with the nationally applicable regulations. In Germany, the intervals of the periodic inspections according to the German Professional Association Provisions (BGV) A3 Section 5 Table 1A (periodic inspections of stationary electrical systems and equipment) must be observed.



# Directory

## List of figures

Fig. 1: Parts of the instructions	5
Fig. 2: Standard lever lock	15
Fig. 3: Lever lock with key size 10 / double-bit 3	15
Fig. 4: Lever lock with key cylinder	15
Fig. 5: Locking cam catch (suction side)	15
Fig. 6: Locking cam catch with emergency lever lock (suction side)	15
Fig. 7: Locking cam catch with retaining mechanism (discharge side)	16
Fig. 8: Locking cam catch with emergency lever lock and retaining mechanism (discharge side)	16
Fig. 9: External lock with key size 10 / double-bit 3	16
Fig. 10: filter wall with equipotential bonding	20
Fig. 11: Assembly sequence	21
Fig. 12: installing the threaded rods	21
Fig. 13: placing the filter	21
Fig. 14: aligning the filter	21
Fig. 15: sliding on clamping sections	22
Fig. 16: incorrect alignment of clamping sections	22
Fig. 17: screwing on the washer and nut	22
Fig. 18: incorrect alignment of clamping sections	22
Fig. 19: 2 Nm tightening torque	23
Fig. 20: incorrect alignment of clamping sections	23
Fig. 21: mounted filter	23
Fig. 22: filter wall with equipotential bonding	23
Fig. 23: earthing strap for the unit floor	29
Fig. 24: equipotential bonding conductor for the flexible connection	29
Fig. 25: Belt tension for the fan with housing	34
Fig. 26: minimum height V	35
Fig. 27: motor removal device structure	36
Fig. 28: minimum distance (V) between corner nodes and load.	36
Fig. 29: A – corner nodes	37
Fig. 30: B – lever chain hoist	37
Fig. 31: C – sling chain	37
Fig. 32: Part designation of the lever chain hoist from the manufacturer Dolezych	38
Fig. 33: Fastening the corner nodes	40

Fig. 34: G – screw locking lacquer	40
Fig. 35: attaching the sling chains to two anchorage eyelets	41
Fig. 36: Load attached wrongly	41
Fig. 37: using the chain shortening hooks	41
Fig. 38: attaching the sling chains to an anchorage eyelet	42
Fig. 39: correct use of corner nodes 1, 2 and 3	43
Fig. 40: wrong use of corner nodes 1, 2 and 3	43
Fig. 41: correct use of corner nodes 1, 3 and 4	43
Fig. 42: load with corner node 4	46
Fig. 43: load in centre of casing with lever chain hoist in corner node 4	46
Fig. 44: load in centre of casing with lever chain hoist in corner node 2	46
Fig. 45: load moves towards corner node 2	46
Fig. 46: Impeller with polyester sling	47
Fig. 47: Lever chain hoists in the corner brackets	47
Fig. 48: Impeller bushing	47
Fig. 51: Pulling out the motor	48
Fig. 52: inspection sticker (lever chain hoist)	49
Fig. 53: inspection mark (sling chain)	49
Fig. 54: Fastening the corner nodes	49
Fig. 55: G – screw locking lacquer	49
Fig. 56: lift out device mounted	52
Fig. 57: factory installed fasteners	53
Fig. 58: parts to be mounted on site	53
Fig. 59: J – lever chain hoist	53
Fig. 60: K – sling chain	53
Fig. 61: Part designation of the lever chain hoist from the manufacturer Dolezych	54
Fig. 62: Inserting the lower centring pin into the groove	56
Fig. 63: Inserting the upper centring pin in the groove	56
Fig. 64: Engaging the mini indexing plunger in the upper suspension bracket	56
Fig. 65: Removing the M8 star grips	57
Fig. 66: Placing the mounting section (B)	57
Fig. 67: Centring the cheese head screws	57
Fig. 68: Screwing on the mounting section (B)	57
Fig. 69: Borehole in the supporting arm (I)	58
Fig. 70: Lifting the supporting arm (I) into the front guide plate	58
Fig. 71: Sliding in the supporting arm (I)	58
Fig. 72: Inserting the supporting arm (I) into the rear guide plate	58

Fig. 73: Positioning the supporting arm for securing with the mini indexing plungers	59
Fig. 74: Securing the supporting arm with mini indexing plungers	59
Fig. 75: Installed lift out device	59
Fig. 76: Fastening the corner nodes	60
Fig. 77: G – screw locking lacquer	60
Fig. 78: centring pin (P) in upper suspension bracket (F)	61
Fig. 79: centring pin (O) in lower suspension bracket (G)	61
Fig. 80: C-M10 mini indexing plunger (C) in upper suspension bracket (F)	61
Fig. 81: cylinder head screws in centring boreholes	62
Fig. 82: M8 star grips in support struts	62
Fig. 83: mini indexing plungers (C) in guide plates	62
Fig. 84: attaching the sling chains to two anchorage eyelets	64
Fig. 85: Load attached wrongly	64
Fig. 86: using the chain shortening hooks	64
Fig. 87: attaching the sling chains to an anchorage eyelet	65
Fig. 88: correct use of corner nodes 1, 2 and 3	66
Fig. 89: wrong use of corner nodes 1, 2 and 3	66
Fig. 90: correct use of corner nodes 1, 3 and 4	66
Fig. 91: load with corner node 4	69
Fig. 92: load in centre of casing with lever chain hoist in corner node 4	69
Fig. 93: load in centre of casing with lever chain hoist in corner node 2	69
Fig. 94: load moves towards corner node 2	69
Fig. 95: Impeller with polyester sling	70
Fig. 96: Lever chain hoists in the corner brackets	70
Fig. 97: Impeller bushing	70
Fig. 100: Pulling out the motor	71
Fig. 101: inner lifting point	72
Fig. 102: external lifting point	72
Fig. 103: load hook in sling chain (K)	72
Fig. 104: load inside the casing	73
Fig. 105: load in intermediate position	73
Fig. 106: load vertically below the outer lever hoist	73
Fig. 107: load outside the casing	73
Fig. 108: load set down	74
Fig. 109: inspection sticker (lever chain hoist)	75
Fig. 110: inspection mark (sling chain)	75
Fig. 111: Fastening the corner nodes	75

Fig. 112: G – screw locking lacquer	75
Fig. 113: centring pin (P) in upper suspension bracket (F)	76
Fig. 114: centring pin (O) in lower suspension bracket (G)	76
Fig. 115: C-M10 mini indexing plunger (C) in upper suspension bracket (F)	76
Fig. 116: cylinder head screws in centring boreholes	77
Fig. 117: M8 star grips in support struts	77
Fig. 118: mini indexing plungers (C) in guide plates	77
Fig. 119: tightening crosswise	84
Fig. 120: tightening crosswise	88
Fig. 121: damper with equipotential bonding conductor	91
Fig. 122: Structure of a dial gauge	98
Fig. 123: pointer (B) below	98
Fig. 124: pointer (B) set correctly	98
Fig. 125: pointer (B) above	99
Fig. 126: pointer (B) set correctly	99
Fig. 127: marking with "+" and "-"	100
Fig. 128: removing the pressure measuring hoses	100
Fig. 129: removing the cuttings	100
Fig. 130: removing the screws	100
Fig. 131: removing the dial gauge	101
Fig. 132: dial gauge removed	101
Fig. 133: Lock with grub screws	102
Fig. 134: Screw in tube connectors	102
Fig. 135: Mount O-ring	102
Fig. 136: Tighten O-rings	102
Fig. 137: Inserting dial gauge	103
Fig. 138: Fasten with screws	103
Fig. 139: Mounting cuttings	103
Fig. 140: Mounting pressure measuring hoses	103
Fig. 141: Dial gauge connected	104
Fig. 142: Zero-point correction	104
Fig. 143: marking with "+" and "-"	105
Fig. 144: removing the pressure measuring hoses	105
Fig. 145: removing the nuts	105
Fig. 146: removing the cuttings	105
Fig. 147: removing the screws	106
Fig. 148: removing the casing	106
Fig. 149: removing the screws	106
Fig. 150: removing the casing	106

---

Fig. 151: dial gauge removed	107
Fig. 152: removing the screws	108
Fig. 153: opening the casing	108
Fig. 154: positioning the casing	108
Fig. 155: fastening the casing	108
Fig. 156: positioning the casing	109
Fig. 157: positioning the casing	109
Fig. 158: removing the nuts	109
Fig. 159: pushing on the cuttings	109
Fig. 160: screwing on the nuts	110
Fig. 161: pushing on the pressure measuring hoses	110
Fig. 162: dial gauge connected	110
Fig. 163: Zero adjustment	110

## Keyword index

<b>A</b>	
Analog differential pressure indicators .....	97
Dial gauge .....	94, 96, 97
<b>C</b>	
Cleaning specialist .....	12
<b>D</b>	
Dial gauge .....	94, 96, 97
In-wall mounting .....	97, 100
Replacement .....	97, 100, 105
Wall mounting .....	105
Dial gauges	
Zero-point correction .....	97, 98, 104, 110
Directory .....	113
Door	
Locking system .....	15
Door lock .....	15
<b>E</b>	
External lock .....	16
<b>H</b>	
Hygiene specialist .....	12
<b>I</b>	
Instructions .....	5
Commissioning .....	5
Disabling and disposal .....	5
Installation and assembly .....	5
Maintenance and cleaning .....	5
Operation and faults .....	5
Transportation and unloading .....	5
<b>L</b>	
List of figures .....	113
<b>M</b>	
Main instructions .....	5
Mechanic .....	12, 35, 51
<b>P</b>	
Person trained in explosion protection .....	12
Personnel qualification .....	12, 111
Pressure measuring devices .....	97
<b>Q</b>	
Qualified electrician .....	12
Qualified electrician in explosion protection .12,	111
Qualified person in accordance with pressure	
equipment regulation .....	12
Qualified person in explosion protection	12, 111



robatherm  
John-F.-Kennedy-Str. 1  
89343 Jettingen-Scheppach

Tel. +49 8222 999 - 0  
[info@robatherm.com](mailto:info@robatherm.com)  
[www.robatherm.com](http://www.robatherm.com)

**robatherm**  
the air handling company